

# Autistic Traits in the General Population

## A Twin Study

John N. Constantino, MD; Richard D. Todd, PhD, MD

**Background:** Recent research has indicated that autism is not a discrete disorder and that family members of autistic probands have an increased likelihood of exhibiting autistic symptoms with a wide range of severity, often below the threshold for a diagnosis of an autism spectrum disorder.

**Objective:** To examine the distribution and genetic structure of autistic traits in the general population using a newly established quantitative measure of autistic traits, the Social Responsiveness Scale (formerly known as the Social Reciprocity Scale).

**Methods:** The sample consisted of 788 pairs of twins aged 7 to 15 years, randomly selected from the pool of participants in a large epidemiologic study (the Missouri Twin Study). One parent of each pair of twins completed the Social Responsiveness Scale on each child. The data were subjected to structural equation modeling.

**Results:** Autistic traits as measured by the Social Responsiveness Scale were continuously distributed and moder-

ately to highly heritable. Levels of severity of autistic traits at or above the previously published mean for patients with pervasive developmental disorder not otherwise specified were found in 1.4% of boys and 0.3% of girls. Structural equation modeling revealed no evidence for the existence of sex-specific genetic influences, and suggested specific mechanisms by which females may be relatively protected from vulnerability to autistic traits.

**Conclusions:** These data indicate that the social deficits characteristic of autism spectrum disorders are common. Given the continuous distribution of these traits, it may be arbitrary where cutoffs are made between research designations of being “affected” vs “unaffected” with a pervasive developmental disorder. The genes influencing autistic traits appear to be the same for boys and girls. Lower prevalence (and severity) of autistic traits in girls may be the result of increased sensitivity to early environmental influences that operate to promote social competency.

*Arch Gen Psychiatry.* 2003;60:524-530

**R**ECENT FAMILY, clinical, and epidemiologic studies have suggested that autistic disorder, as currently characterized in *DSM-IV*, represents the upper extreme of a constellation of deficits in social and communicative behavior that may be continuously distributed in nature.<sup>1-5</sup> Autistic disorder is subsumed under the *DSM-IV* category, pervasive developmental disorders (PDDs), a group of disorders that are distinguished from other psychiatric disorders by the presence of (1) deficits in reciprocal social behavior, variously accompanied by (2) deficits in communication, and/or (3) repetitive or stereotyped behaviors. With the exception of Rett syndrome (a rare disorder caused by a point mutation on the X chromosome), PDDs affect males much more commonly than females (prevalence ratio, ~4:1<sup>6</sup>).

The *DSM-IV* diagnostic criteria for PDDs are focused on establishing the presence or absence of categorically defined symptoms in the 3 criterion domains just described. In doing so, they incorporate arbitrary judgments about the degree of deficiency that must be present for the criteria to be met. Difficulties inherent in interpreting the current diagnostic criteria for PDDs (especially PDD not otherwise specified [PDD-NOS], which is the most common type and involves atypical or milder autistic symptoms) have complicated epidemiologic research on these conditions. Recently, 2 epidemiologic studies<sup>7,8</sup> that used screening and follow-up assessment of very large numbers of young children have placed the prevalence of PDD at about 60 per 10000, which is higher than what had been inferred from previous research involving clinic-based studies and epidemiologic surveys.

From the Departments of Psychiatry (Drs Constantino and Todd), Pediatrics (Dr Constantino), and Genetics (Dr Todd), Washington University School of Medicine, St Louis, Mo.

Most cases of autism follow an oligogenic pattern of inheritance, with heritability estimates of 0.6 to 0.9.<sup>4,9,10</sup> Family studies and clinical reports have provided evidence for substantial genetic overlap among the 3 most common PDDs (autistic disorder, Asperger disorder, and PDD-NOS), but the studies have not been large enough to be conclusive about the magnitude of that overlap.<sup>11</sup> Spiker et al<sup>4</sup> reported that in a sample of 351 autistic siblings of 171 autistic probands, autistic symptoms were best characterized along a single, heritable, continuous severity dimension. Piven et al<sup>3</sup> observed that mild (sub-threshold) autistic traits aggregated in the nonautistic family members of autistic probands.

Given the evidence that there is a broad range of severity of autistic traits, that traits of varying levels of severity might share common genetic determinants, and that, to our knowledge, there are no previous studies of the prevalence of subthreshold autistic traits (autistic traits of a severity level that falls below the threshold for a diagnosis of a PDD), we undertook the present study. We were motivated in part by the possibility that even mild variations of autistic traits, if common, may be responsible for incurring considerable social impairment and cost in terms of public health. We examined the epidemiologic and genetic structure of autistic traits in a population-based twin sample that included same-sex and opposite-sex twin pairs. Exploration of the genetic structure of autistic traits in such a sample offered the possibility of gaining insights into the causes of such deficits and of the pronounced sex differences that are observed in the prevalence of PDD symptoms.

The method for conducting such a study depended on the development of a quantitative measure of autistic traits, since previously established autism rating scales had been designed to establish "caseness" in a clinical sense (ie, for ruling in or out categorical diagnoses of autism). For this reason, we previously developed and tested the Social Responsiveness Scale (SRS).<sup>12</sup> (This was formerly known as the Social Reciprocity Scale, but there was no change in content when the instrument was re-named.) The SRS is a 65-item questionnaire that has demonstrated the capability of distinguishing children with PDDs from those with other childhood psychiatric conditions and from normal controls.<sup>1</sup> Although there are many different ways in which social development can be impaired as a function of psychiatric disorder, the SRS was designed specifically to tap social deficits (primarily involving reciprocal social behavior) that are inherent in PDDs (in contrast with those incurred by other psychiatric conditions). Social deficits ascertained by the SRS are generally unrelated to IQ,<sup>1,13</sup> are highly heritable in males,<sup>2</sup> and are influenced by genetic factors that are independent from those that influence psychiatric conditions outside the autistic spectrum.<sup>14</sup> The SRS is advantageous for large-scale epidemiologic studies because it requires only 15 to 20 minutes to complete.

Items representing all 3 criterion domains for autism (social deficits, communicative deficits, and restricted/stereotypic behaviors or interests) are included in the SRS. Although previous research in clinical samples has suggested the possibility that specific subdomains of the autistic phenotype (restricted/stereotypic behavior and

age of onset of speech) may follow independent patterns of inheritance<sup>15</sup> and that such elements may operate independently from one another over the course of development,<sup>16</sup> other clinical and genetic data have suggested the contrasting possibility that the various symptoms of autism are attributable to a singular underlying deficit.<sup>4</sup> Congruent with this latter possibility, factor analysis and latent class analysis of SRS data from population-based samples<sup>1,14</sup> has failed (thus far) to demonstrate the existence of separable clusters of deficiency for the 3 criterion domains for autism. Rather, deficits across all 3 domains have appeared attributable to a single underlying continuously distributed variable, characterized by general impairment in reciprocal social behavior for which a single index score is generated by the SRS.

## METHODS

### SAMPLE

During 1999-2001, the SRS was completed by 1 parent (97% were mothers) on each twin of 788 twin pairs aged 7 to 15 years, randomly selected from the pool of participants in the Missouri Twin Study.<sup>17</sup> In the Missouri Twin Study, twin births were identified from public birth records, and 65% of the twin births from each calendar year were randomly selected for contact. We traced 93.5% of families and completed a zygosity interview with 1 parent from each family. Initial behavior assessments of the twins from these families were obtained by mail, with a response rate of 60.7%. A random sample of the responders was selected to complete the SRS and return it to the investigators by mail. The response rate for completing the SRS on both members of a twin pair was 84%. The sample consisted of 219 male-male pairs (91 monozygotic [MZ], 128 dizygotic [DZ]; mean  $\pm$  SD age, 11.2  $\pm$  1.8 years), 319 female-female pairs (177 MZ, 142 DZ; age, 11.6  $\pm$  1.5 years), and 250 opposite-sex pairs (age, 12.0  $\pm$  1.7 years). The sample was predominantly European American (by self-report), with 12.5% African American respondents and less than 1% of other ethnicity (by parent report) among participants. There were no significant differences between responders and nonresponders with respect to child's age, sex, self-reported ethnicity, race, rural/urban residency, divorced/married status of parents, or median household income (as judged by 1990 census tract data).

### MEASURES

The SRS is a 65-item parent and/or teacher report questionnaire designed to assess autistic symptoms as a quantitative trait.<sup>12,13</sup> It requires 15 to 20 minutes to complete. The instrument inquires about specific and observable elements of reciprocal social behavior (39 items), social use of language (6 items), and behaviors characteristic of children with autism and other PDDs (20 items), and it generates a singular scale score, as discussed in the introduction. Higher scores on the SRS indicate higher degrees of social impairment. The psychometric properties of the SRS have been previously described in reports of studies involving more than 900 children aged 4 to 18 years.<sup>1,2,13,14</sup> Intraclass correlation coefficients for test-retest reliability ( $\leq$ 27 months) have been found to be about 0.80.<sup>1,13</sup> Furthermore, interrater reliability of about 0.75 has been observed in comparisons of SRS assessments by mothers, fathers, and teachers.<sup>13</sup>

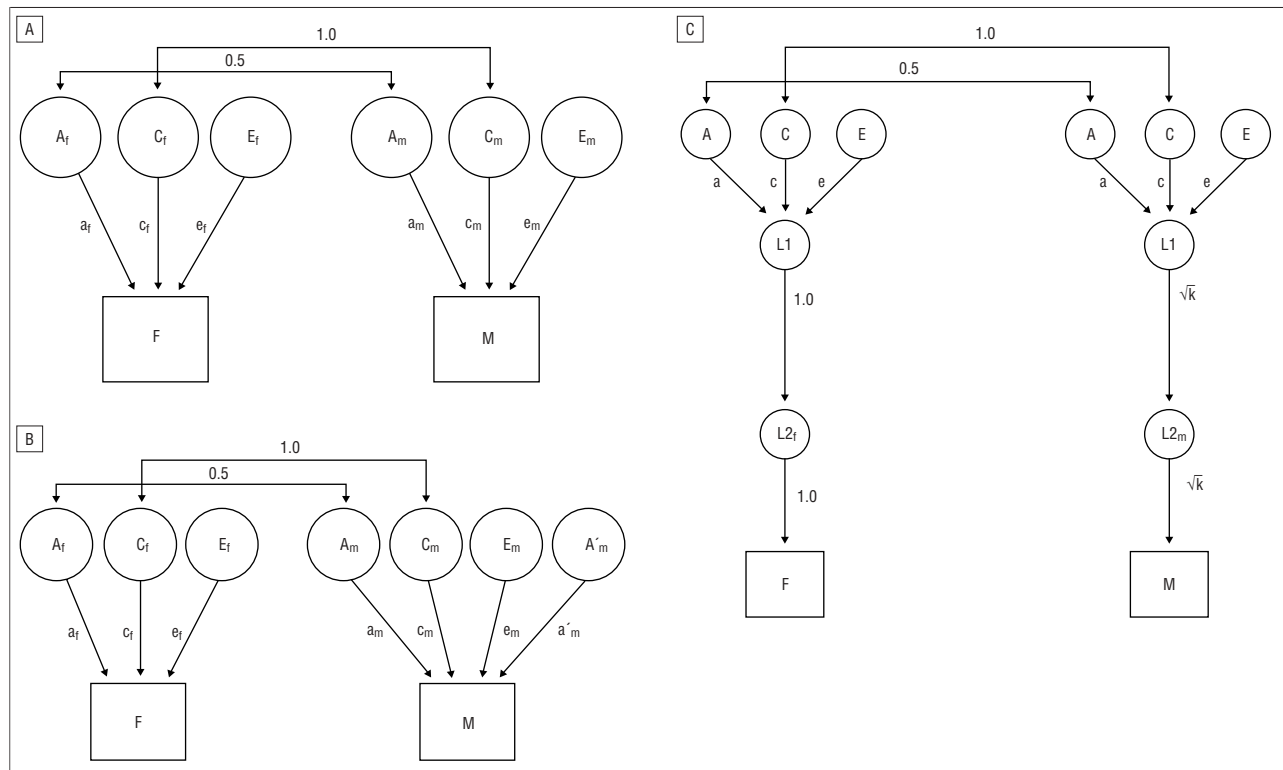

**Figure 1.** A, Common effects sex-limitation model (for opposite-sex twin pair). B, General sex-limitation model (for opposite-sex twin pair). C, Scalar sex-limitation model (for opposite-sex twin pair). For all path models shown, A indicates additive genetic influences; M, male phenotype (observed); C, common environmental influences; F, female phenotype (observed); E, unique environmental influences; L, latent phenotype; A', sex-specific genetic influences; and k, scalar coefficient. The subscripts *m* and *f* indicate that the model allows for the influence of the respective variable on the phenotype to vary in magnitude as a function of sex, and therefore, that separate variables for males and females have been incorporated into the model.

## DATA ANALYSIS

Following the implementation of descriptive statistical procedures, multiple linear regression analysis was employed to determine the extent to which age and sex were associated with SRS scores in the sample. Next, twin A and twin B SRS data were incorporated into separate variance-covariance matrices for all 5 types of twin pairs involved in the study (male-male MZ pairs, male-male DZ pairs, female-female MZ pairs, female-female DZ pairs, and opposite-sex DZ pairs). The data were then subjected to structural equation modeling (SEM) to determine the best fitting models of causation for autistic traits measured by the SRS. The results of model fitting for the male-male pairs have been previously reported.<sup>2</sup> For female-female pairs, models that incorporated all possible combinations of additive genetic influences, dominant genetic influences, common environmental influences, unique environmental influences, age effects, rater contrast (indistinguishable from sibling interaction effects in this design), and rater bias were tested to determine the best fitting univariate model (see Hudziak et al<sup>17</sup> for a more complete discussion of these types of models).

Structural equation modeling involves the use of path models that mathematically represent the totality of causal influences on the trait of interest. To quantify the degree of “fit” between observed data (in this case, separate variance and covariance statistics for MZ and DZ twins) and what would be expected from a given mathematical model of causality, the maximum likelihood method is employed and generates a goodness-of-fit statistic that follows a  $\chi^2$  distribution. For any given model, a lower  $\chi^2$  fit statistic (and higher corresponding *P* value) in comparison with the  $\chi^2$  value for a model with 1 more or 1 less parameter represents improved goodness-of-fit over the latter. In general, more parsimonious models (with fewer vari-

ables) are favored over more complex models if their statistics for goodness-of-fit are similar. For all SEM analyses, we used the statistical software program Mx.<sup>18,19</sup>

Next, using all of the available twin data (including that from opposite-sex pairs), we examined the nature of discrepancies in the genetic structure of autistic traits between boys and girls by testing a series of sex limitation models. The first set of models that were tested incorporated only those parameters that were components of the best fitting models in the univariate analyses for male-male pairs and female-female pairs. These models, termed “common effects sex limitation models,” assumed that the salient genetic and environmental influences on autistic traits in boys and girls were identical but could differ in magnitude across sexes, as illustrated schematically for opposite-sex pairs in **Figure 1A**. A second set of models additionally assumed the presence of sex-specific genetic influences to account for variation in autistic traits between boys and girls, as shown in **Figure 1B**. A final set of models (scalar sex limitation models, **Figure 1C**) assumed that sex differences resulted from the effects of scalar amplification or dampening (in one sex) of the phenotypic manifestations of traits whose underlying causal influences were identical in magnitude across sexes. Calculations derived from these 3 sets of models represent the extent of genetic information on sex differences that is available from single-generation twin designs that include both same-sex and opposite-sex pairs (Michael C. Neale, e-mail communication, 2002).

## RESULTS

The distribution of SRS scores, plotted separately for boys and girls, is shown in **Figure 2**. The mean  $\pm$  SD score

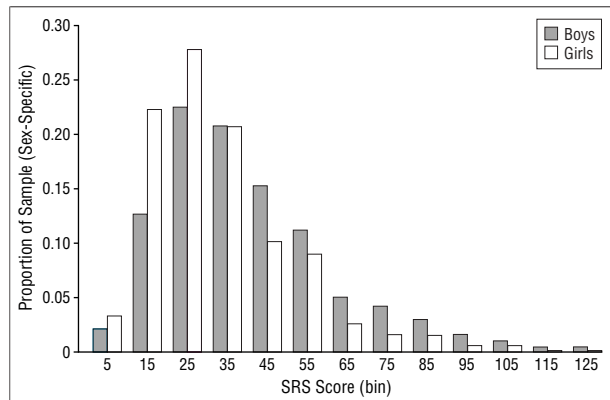

**Figure 2.** Distribution of Social Responsiveness Scale (SRS) scores as a function of sex (n=1576).

for boys was  $35.3 \pm 22.0$  and for girls was  $27.5 \pm 18.4$  ( $t_{1578} = 7.63$ ,  $P < .001$ ). Controlling for the effects of sex (which explained 3% of the variation in SRS scores), linear regression analysis revealed a minimal effect of age on SRS scores in this sample of 7- to 15-year-olds (age coefficient,  $-0.54$ ;  $t_2 = -1.79$ ,  $P = .07$ ). Using as a cutoff the previously published mean score for boys with PDD-NOS (101.5), 1.4% of boys and 0.3% of girls had SRS scores at or above this cutoff (Fisher exact test,  $P = .03$ ). Exploration of the genetic structure of SRS scores in boys and girls was next conducted to identify possible causal mechanisms for these sex discrepancies.

Twin-twin correlations and variance-covariance matrices are presented for each twin type (male-male MZ pairs, male-male DZ pairs, female-female MZ pairs, female-female DZ pairs, and opposite-sex DZ pairs) in **Table 1**. In computing the variance-covariance data, all raw SRS data were square root transformed to minimize skew and kurtosis, since SEM assumes normal distribution of data. Results of model fitting for the male-male pairs were described in a previous report<sup>2</sup>; briefly, the best fitting model incorporated only additive genetic influences (parameter estimate, 0.76; 95% confidence interval [CI], 0.68-0.80) and unique environmental influences (parameter estimate, 0.24; 95% CI, 0.18-0.29).

This is the first report of SEM applied to SRS data from same-sex female pairs and opposite-sex pairs. Summaries of the results of our analyses for female-female pairs are presented in **Table 2**. The best fitting models for the girls involved additive genetic factors, unique environmental factors, and either common environmental influences (ACE model [additive genetic (A), shared environment (C), and nonshared environment (E)]) or sibling interaction effects (AEs) model. The ACE model was the superior of the 2 and yielded an estimate of 0.40 (95% CI, 0.27-0.51) for the magnitude of genetic influences on SRS scores in girls.

Incorporation of the data from all twin types, including opposite-sex pairs, allowed testing of specific hypotheses regarding the likely cause of the observed discrepancies in the genetic structure of autistic traits between boys and girls. Using the covariance data from all 5 twin types presented in Table 1, model fitting proceeded using the parameters found to exert substantive causal influences on SRS scores in the best fitting models from the respective analyses of same-sex pairs (described

**Table 1. Variance-Covariance Statistics for Square Root-Transformed Social Responsiveness Scale (SRS) Scores**

	Twin 1 SRS-t*	Twin 2 SRS-t*
MZ boys: n = 91; r = 0.73		
Twin 1 SRS-t	2.941	
Twin 2 SRS-t	2.301	3.085
MZ girls: n = 177; r = 0.79		
Twin 1 SRS-t	2.444	
Twin 2 SRS-t	2.059	2.699
DZ boys: n = 128; r = 0.37		
Twin 1 SRS-t	3.290	
Twin 2 SRS-t	1.519	3.292
DZ girls: n = 142; r = 0.63		
Twin 1 SRS-t	2.806	
Twin 2 SRS-t	1.902	3.206
DZ opposite-sex pairs: n = 250; r = 0.59		
	<b>F Twin SRS-t*</b>	<b>M Twin SRS-t*</b>
F twin SRS-t	2.976	
M twin SRS-t	1.827	3.209

Abbreviations: DZ, dizygotic; MZ, monozygotic.

\*Coefficients for twin-twin correlation (using untransformed SRS scores).

above). These parameters were incorporated into 3 separate sex-limitation paradigms, for which twin designs are capable of differentiating goodness-of-fit to the data through statistical modeling. For each of the 3 paradigms, all possible combinations of parameters for additive genetic, common environmental, unique environmental, and sibling interaction effects were compared.

A summary of goodness-of-fit statistics derived from these analyses is presented in **Table 3**. It is important to note that within each sex-limitation paradigm, the models are hierarchically nested, such that it was possible to directly compare the fit indices ( $c^2$ ,  $P$ , and Akaike information criterion) to determine which model fits best. Interpreting differences-in-fit indices across paradigms is less precise because in such comparisons, the models are not nested. The primary finding was that although heritability estimates for boys were substantially higher than for girls in the univariate analyses, there was no evidence for the existence of sex-specific genetic influences. According to the analyses summarized in Table 3, sex disparities in the phenotypic manifestations of autistic traits in this sample are attributable to 1 of (or the combination of) 2 possible mechanisms, listed here in order of parsimony. The first is a mechanism in which sex differences are brought about by scalar amplification (in boys) or dampening (in girls) of causal influences that are identical in magnitude across sexes. This mechanism is represented by the kACE model in Table 3. The second (represented by the ACEace and ACEaceY models in Table 3) is a mechanism by which boys and girls are differentially influenced by common environmental factors, and to some degree, differentially influenced by a shared set of additive genetic influences.

#### COMMENT

We found that in the general population, characteristics of social behavior measured by the SRS are (1) com-

**Table 2. Structural Equation Modeling of Square Root–Transformed Social Responsiveness Scale Scores in Female Twins\***

Model	ML $\chi^2$	P	AIC†	df	A <sup>2</sup> (95% CI)	C <sup>2</sup> (95% CI)	E <sup>2</sup> (95% CI)	rc/ Sibling Interactions
ACE	3.53	0.32	-2.48	3	0.40 (0.27-0.51)	0.41‡ (0.25-0.51)	0.19 (0.16-0.22)	NA
AES	5.50	0.14	-0.50	3	0.68 (0.57-0.74)		0.31 (0.25-0.38)	0.01 (0.002-0.03)

Abbreviations: ACE, additive genetic (A), shared environment (C), and nonshared environment (E) model; AE, sibling interaction effects additive genetic and nonshared environment; AIC, Akaike information criterion; ML, maximum likelihood; NA, not applicable.

\*This table presents univariate fit statistics and parameter estimates for the best fitting models. Models that incorporated parameters for dominant genetic influences, age, or rater contrast effects resulted in significantly poorer fit to the data. Univariate analyses of twin data from a single generation are not capable of distinguishing common environmental influences from rater bias effects. However, neither were found to be present in a previous sample involving male twins.<sup>2</sup>

†The AIC, defined as  $\chi^2 + 2$ . This is a fit statistic that incorporates consideration of the degree of parsimony of the model. Lower values indicate improved goodness-of-fit. Values greater than 0.0 reflect a poor fit of the model to the observed data.<sup>19</sup>

‡Path coefficient was negative, indicating that this influence operates to lower Social Responsiveness Scale scores.

**Table 3. Fit Statistics for Structured Equation Modeling of Square-Root-Transformed Social Responsiveness Scale (SRS) Scores, Using Variance-Covariance Data for All Twin Pairs in the Study\***

Model†	ML $\chi^2$	P Value	AIC	df	Girls			Boys			Sex Specific Y <sup>2</sup>	Scalar Coefficient k
					A <sup>2</sup>	C <sup>2</sup>	E <sup>2</sup>	a <sup>2</sup>	c <sup>2</sup>	e <sup>2</sup>		
Best fitting common effects sex limitation model ACEace	5.97	.74	-12.03	9	0.39 (0.27-0.49)	0.43 (0.31-0.51)	0.18 (0.15-0.22)	0.51 (0.28-0.58)	0.25 (0.14-0.36)	0.23 (0.18-0.29)	NA	NA
Best fitting general sex limitation model (sex-specific genetic influences) ACEace Y	5.97	.65	-10.03	8	0.39 (0.27-0.49)	0.43 (0.31-0.51)	0.18 (0.15-0.22)	0.51 (0.28-0.58)	0.25 (0.14-0.36)	0.23 (0.18-0.29)	0.00	NA
Best fitting scalar sex limitation model kACE	10.46	.49	-11.54	11	0.48 (0.40-0.54)	0.32 (0.23-0.40)	0.20 (0.17-0.23)	0.48	0.32	0.20	NA	1.08

Abbreviations: ACE, additive genetic (A), shared environment (C), and nonshared environment (E) model (uppercase, girls; lowercase, boys); AIC, Akaike information criteria; ML, maximum likelihood; NA, not applicable; Y, sex-specific genetic influences.

\*Data are given as standardized parameter estimates (95% confidence interval) for best fitting model in each category unless otherwise indicated. ACEace and AEace models had uniformly poor fit with or without the addition of sex-specific or scalar parameters; they are omitted from the sex-specific and scalar categories for clarity.

†The letter abbreviations in each row heading indicate which parameters were incorporated into the model whose fit statistics are presented in that row. In the kACE model, A, C, and E are constrained to be equal in magnitude between boys and girls. In the other models, boys and girls are allowed to differ in the extent to which they are affected by the same sets of causal influences.

mon; (2) continuously distributed; (3) moderately to highly heritable; (4) influenced by the same additive genetic factors in boys and girls; and (5) exhibit no evidence of nonadditive genetic factors. The magnitude of genetic influences in boys was in close keeping with heritability estimates derived from twin and family studies of autism, the subjects of which have been mostly boys.<sup>4,9</sup> The mean SRS score for girls was 25% lower than that for boys; 1.4% of boys and 0.3% of girls had levels of severity of autistic traits that were at or above the previously published mean score for boys with PDD-NOS. In comparison, a recent 4-stage community survey of young children in the United Kingdom found the prevalence of all PDDs to be 0.6%, with a boy-girl ratio of 4:1.<sup>7</sup>

The notion that the psychological characteristics measured by the SRS represent a specific domain of social development that is distinguishable from other domains of social or psychological impairment has been supported by several key findings from previous research. First, mean

SRS scores for children with PDDs are more than 2 SDs higher than mean scores for normal children or for children with other psychiatric disorders.<sup>1</sup> Second, SRS scores are essentially unrelated to IQ<sup>1,13</sup> and strongly correlate with DSM-IV algorithm scores from the Autism Diagnostic Interview–Revised, which is a research standard for establishing a diagnosis of autistic disorder.<sup>13</sup> Finally, in the male-male twin pairs described in this study, social impairments ascertained using the SRS were found to be largely genetically independent from other domains of psychopathologic behavior.<sup>14</sup> Only when the specific causal influences (both genetic and environmental) on subthreshold autistic traits (as measured by the SRS) are better understood and are distinguished from those of other domains of social deviance (eg, shyness, extraversion, sociopathy, personality disorder) will it be possible to better understand the relationship between the presence of subthreshold autistic traits and the presence or absence of other specific disorders of social development.

As far as the causes of sex differences in these traits are concerned, we found no evidence to suggest the existence of sex-specific genetic influences. Rather, sex differences appear to arise from discrepant phenotypic manifestations of genetic and environmental influences that are common to both sexes. Two different models for these sex effects explain the data equally well. In one model, girls appear to be more sensitive than boys to common environmental influences that improve their capacity for reciprocal social behavior and thereby reduce the penetrance of genetic liability for autistic traits. The other model (of comparable goodness-of-fit) shows that girls experience a phenotypic dampening (in comparison with boys) of the genetic and environmental influences that operate to bring about autistic traits. This effect could potentially be brought about by the phenomenon of X-inactivation<sup>20</sup> or by an imprinted X liability threshold mechanism. The latter fits theoretically with existing family data on autism and has been implicated in other neurodevelopmental disorders.<sup>21</sup> It involves elevation of the threshold for phenotypic expression of a trait by a gene that is expressed on paternally transmitted (but not maternally transmitted) X chromosomes.

In one respect, the genetic structure for SRS scores differs from what has been previously reported for autism spectrum conditions in that we observed relatively high correlation coefficients for nonidentical (DZ) twins. This suggests that the sibling recurrence rate for autistic traits may be higher than the 5% to 10% inferred from clinical studies (in which the status of being affected is defined in a categorical sense). Le Couteur et al<sup>22</sup> and Bolton et al<sup>23</sup> showed that when diagnostic criteria were relaxed from a full diagnosis of autism to the "broader autism phenotype," the DZ twin concordance rate increased substantially. The same may hold true if the criteria for ascertaining these deficits are relaxed even further to encompass the entire range of autistic deficits that occur in nature. This has important implications for genetic studies as well, since MZ/DZ concordance ratios greater than 2 (which we did not observe in our sample but which have been consistently reported in previous studies of clinically ascertained twins with autism) have been a primary reason for inferring the existence of epistatic interactions between multiple loci in autism.

Finally, the results of our study suggest that future research into the causes of autism (particularly genetic linkage studies) might be facilitated by measuring autistic symptoms as quantitative traits. Inclusion of less severely affected subjects would allow for the recruitment of larger sample sizes than have previously been obtainable in studies of categorically defined autism. Moreover, in discordant sibling pair designs involving boys, the SRS might prove particularly useful in characterizing unaffected siblings since there are minimal floor effects for the measure (individuals with extremely low levels of impairment are reliably identifiable). Thus, measuring autistic symptoms as quantitative traits might enhance the statistical power of genetic studies and avert the problem of misclassification, which can be particularly damaging to genetic linkage analyses. Two recent studies of autism that used research methods distinct from ours (a large clinical-family study<sup>4</sup> and a study of autis-

tic symptoms in adults<sup>24</sup>) have provided compelling confirmatory evidence for the existence of a continuous severity gradient for autistic symptoms. This suggests that it may be arbitrary where cutoffs should be made for research definitions of "caseness."

Potential limitations of the study are that it involved only twins, and that despite its large sample size, the CIs on parameter estimates for genetic and environmental influences were relatively wide. Genetically informative samples involving larger numbers of subjects across a wider range of ages and multiple generations will be necessary to definitively resolve questions about more complex mechanisms of inheritance than were testable using this design. Although we did not observe statistically significant age effects in this sample of 7- to 15-year-olds, developmental changes in the magnitude of social impairment may occur in severely affected children or in subjects outside this age range. To date, our research involving population-based samples of singletons<sup>1</sup> has yielded highly similar findings to what were reported here in terms of mean SRS scores, minimal age effects in this age range, and continuous distribution of deficits.

It is important to keep in mind that this was a study of autistic traits rather than of PDDs. Level of functional adaptation, which is an essential parameter for the designation of any disorder, was not directly ascertained in this study (although we note that the wording of many SRS items implies impairment). Furthermore, it is not yet known whether the causal influences on the autistic traits that we ascertained in the general population are the same as those responsible for most cases of clinically defined PDDs, including autism. Family studies of clinically ascertained subjects are under way to explore this issue; previous studies have already shown that subthreshold autistic traits aggregate in the nonautistic family members of autistic probands.<sup>3</sup> If this holds true in subsequent research, the genetic information from this study has direct relevance to understanding autism itself, as well as the nature of consistently observed sex differences in the prevalence of PDDs. Even if the genetic underpinnings of subthreshold autistic traits turn out to be distinct from those of clinically defined autism, the former are important to understand from a genetic-epidemiologic perspective because of their prevalence and potential implications for social development in children in the general population. One important example of this is that the sex differences identified in this population-based study may relate to universally observed differences between boys and girls in broader aspects of social behavior. It is also conceivable that in certain individuals or in specific environmental contexts, subthreshold autistic traits might confer adaptive advantages.<sup>24</sup>

In cases where the effects of these traits are deleterious, measuring the deficits through the use of quantitative measures may prove useful for predicting clinical course, sharing clinical information across disciplines, and monitoring the effects of specific treatments. Through such uses, it may be determined whether less severely affected children are actually more responsive to early interventions than their more severely affected counterparts. Our findings on the possible differential respon-

sivity of girls to compensatory environmental influences warrant future studies of the potential role of environmental interventions that might be applied early in the lives of all affected children.

Submitted for publication April 11, 2002; final revision received July 12, 2002; accepted November 8, 2002.

This work was supported by grants HD39663 (Dr Constantino) and grants MH52813, MH65671, and MH31302 (Dr Todd) from the National Institutes of Health, Bethesda, Md.

Corresponding author and reprints: John N. Constantino, MD, Department of Psychiatry, Washington University School of Medicine, 660 S Euclid Ave, Campus Box 8134, St Louis, MO 63110 (e-mail: constantino@psychiatry.wustl.edu).

## REFERENCES

1. Constantino JN, Przybeck T, Friesen D, Todd RD. Reciprocal social behavior in children with and without pervasive developmental disorders. *J Dev Behav Pediatr.* 2000;21:2-11.
2. Constantino JN, Todd RD. Genetic structure of reciprocal social behavior. *Am J Psychiatry.* 2000;157:2043-2045.
3. Piven J, Palmer P, Jacobbi D, Childress D, Arndt S. Broader autism phenotype: evidence from a family history study of multiple-incidence autism families. *Am J Psychiatry.* 1997;154:185-190.
4. Spiker D, Lotspeich LJ, Dimiceli S, Myers RM, Risch N. Behavioral phenotypic variation in autism multiplex families: evidence for a continuous severity gradient. *Am J Med Genet.* 2002;114:129-136.
5. Waterhouse L, Morris R, Allen D, Dunn M, Fein D, Feinstein C, Rapin I, Wing L. Diagnosis and classification in autism. *J Autism Dev Disord.* 1996;26:59-86.
6. Fombonne E, Simmons H, Ford T, Meltzer H, Goodman R. Prevalence of pervasive developmental disorders in the British Nationwide Survey of Child Mental Health. *J Am Acad Child Adolesc Psychiatry.* 2001;40:820-827.
7. Chakrabarti S, Fombonne E. Pervasive developmental disorders in preschool children. *JAMA.* 2001;285:3093-3099.
8. Baird G, Charman T, Baron-Cohen S, Cox A, Swettenham J, Wheelwright S, Drew A. A screening instrument of autism at 18 months of age: a 6 year follow-up study. *J Am Acad Child Adolesc Psychiatry.* 2000;39:694-702.
9. Folstein SE, Rosen-Sheidley B. Genetics of autism: complex aetiology for a heterogeneous disorder. *Nat Genet.* 2001;2:943-955.
10. Bailey A, Palferman S, Heavey L, Le Couteur A. Autism: the phenotype in relatives. *J Autism Dev Disord.* 1998;28:369-392.
11. Volkmar FR, Klin A, Pauls D. Nosological and genetic aspects of Asperger syndrome. *J Autism Dev Disord.* 1998;28:457-463.
12. Constantino JN. *The Social Responsiveness Scale.* Los Angeles, Calif: Western Psychological Services; 2002.
13. Constantino JN, Davis SA, Reich W, Schindler MK, Gross MM, Brophy SL, Metzger LM, Shoushtari CS, Splinter R, Todd RD. Validation of a brief quantitative measure of autistic traits: comparison of the Social Responsiveness Scale with the Autism Diagnostic Interview-Revised. *J Autism Dev Disord.* In press.
14. Constantino JN, Hudziak JJ, Todd RD. Deficits in reciprocal social behavior in male twins: evidence for a genetically independent domain of psychopathology. *J Am Acad Child Adolesc Psychiatry.* In press.
15. Silverman JM, Smith CJ, Schmeidler J, Hollander E, Lawlor BA, Fitzgerald M, Buxbaum JD, Delaney K, Galvin P. Symptom domains in autism and related conditions: evidence for familiarity. *Am J Med Genet.* 2002;114:64-73.
16. Robertson JM, Tanguay PE, L'Ecuyer S, Sims A, Waltrip C. Domains of social communication handicap in autism spectrum disorder. *J Am Acad Child Adolesc Psychiatry.* 1999;38:738-745.
17. Hudziak JJ, Rudiger LP, Neale MC, Heath AC, Todd RD. A twin study of inattentive, aggressive and anxious/depressed behaviors. *J Am Acad Child Adolesc Psychiatry.* 2000;39:469-476.
18. Neale MC. *Mx: Statistical Modeling* [computer program]. 5th ed. Richmond, Va: Virginia Commonwealth University, Dept of Psychiatry 1999.
19. Neale MC, Cardon LR. *Methodology for Genetic Studies of Twins and Families.* Boston, Mass: Kluwer Academic; 1992.
20. Wolff DJ, Schwartz S, Montgomery T, Zackowski JL. Random X inactivation in a girl with a balanced t(X;9) and an abnormal phenotype. *Am J Med Genet.* 1998;77:401-404.
21. Skuse DH. Imprinting, the X-chromosome, and the male brain: explaining sex differences in the liability to autism. *Pediatr Res.* 2000;47:9-16.
22. Le Couteur A, Bailey A, Goode S, Rutter M. A broader phenotype of autism: the clinical spectrum in twins. *J Child Psychol Psychiatry.* 1996;37:785-801.
23. Bolton A, Macdonald H, Pickles A, Rios P, Goode S, Crowson M, Bailey A, Rutter M. A case-control family history study of autism. *J Child Psychol Psychiatry.* 1994;35:877-900.
24. Baron-Cohen S, Wheelwright S, Skinner R, Martin J, Clubley E. The Autism-Spectrum Quotient (AQ): evidence from Asperger syndrome/high-functioning autism, males and females, scientists and mathematicians. *J Autism Dev Disord.* 2001;31:5-17.