

Role of Genes and Environments for Explaining Alzheimer Disease

Margaret Gatz, PhD; Chandra A. Reynolds, PhD; Laura Fratiglioni, MD, PhD; Boo Johansson, PhD; James A. Mortimer, PhD; Stig Berg, PhD; Amy Fiske, PhD; Nancy L. Pedersen, PhD

Context: Twin studies using selected samples have shown high heritability for Alzheimer disease (AD).

Objective: To evaluate genetic and environmental influences on AD in a fully ascertained population of older twins, including like- and unlike-sex pairs.

Design: Five-group quantitative genetic model: male monozygotic twins, female monozygotic twins, male dizygotic twins, female dizygotic twins, and unlike-sex twins.

Setting and Participants: All twins in the Swedish Twin Registry aged 65 years and older. The study included 11 884 twin pairs, among whom were 392 pairs in which 1 or both members had AD.

Main Outcome Measures: All individuals were screened for cognitive dysfunction. Suspected cases of dementia and their co-twins received complete clinical diagnostic evaluations for AD. Estimates of heritability, shared environmental influences, and nonshared envi-

ronmental influences, adjusting for age, were derived from the twin data.

Results: Heritability for AD was estimated to be 58% in the full model and 79% in the best-fitting model, with the balance of variation explained by nonshared environmental influences. There were no significant differences between men and women in prevalence or heritability after controlling for age. Within pairs concordant for AD, intrapair difference in age at onset was significantly greater in dizygotic than in monozygotic pairs, suggesting genetic influences on timing of the disease.

Conclusions: In the largest twin study to date, we confirmed that heritability for AD is high and that the same genetic factors are influential for both men and women. However, nongenetic risk factors also play an important role and might be the focus for interventions to reduce disease risk or delay disease onset.

Arch Gen Psychiatry. 2006;63:168-174

ALZHEIMER DISEASE (AD) IS a major public health issue, with prevalence of dementia from 6% to 10% in adults aged 65 years and older, of which approximately two thirds of the cases are AD.¹ With the population of older adults increasing, the number of cases will increase. Understanding the risk factors for AD can direct investigations of ways to reduce disease occurrence.² A number of genetic risk factors have been identified, but only a small proportion of AD cases can be explained by specific gene mutations.¹ Empirical support for specific environmental risk or protective factors has often been inconsistent.^{1,3}

Twin studies offer a special design for teasing apart the relative importance of genetic and environmental influences. The history of twin studies of AD ranges from case studies of 1 or a few twin pairs⁴⁻⁷ to use of established twin registries⁸⁻¹³ where the number of cases of AD ranges from un-

der 40^{9,11,12} to 94.¹⁰ The present report is based on the largest population-based twin study of AD to date, which includes sufficient numbers of like- and unlike-sex twin pairs to examine sex differences in genetic or environmental effects. Further, we are the first to adjust for age in estimating the relative contributions of genetic and environmental influences on AD occurrence.¹⁴

In a twin study, the most basic descriptive information is whether a twin pair is concordant (both have the disorder) or discordant (only 1 is affected). To the extent that monozygotic (MZ) twins are more concordant for a disease than dizygotic (DZ) twins, genetic influences are suggested. In a population-based twin study, it is possible to estimate the relative contribution of genetic and environmental influences on a trait or disease. These estimates are based on the fact that MZ twins share all of their genes while DZ twins share on average 50% of their segregat-

Author Affiliations are listed at the end of this article.

ing genes. Evidence for the role of the environment comes from MZ twin pairs who are discordant for the disease. Differences between the twin with the disease and the twin without the disease can provide clues regarding biological markers of AD that differentiate the affected from the unaffected twin⁷ or provide information related to which environmental risk factors might have led one twin to have the disorder while sparing the other.^{6,15}

Studies of rates of concordance in twins who have volunteered for research can be biased if, for example, pairs who are concordant or MZ pairs are more likely to volunteer. For this reason, use of a twin registry that was compiled from a population from which cases were ascertained in an unbiased fashion is essential. Age effects are also critical to address in twin studies, particularly for age-dependent traits such as AD. If age is not appropriately handled, inflated shared (ie, familial) environmental effects will be obtained.¹⁶

Including unlike-sex twin pairs in the study permits asking additional questions. Not only can heritability and environmental influences be quantitatively compared for men and for women, but also comparing similarity for like- and unlike-sex pairs tests whether the same genes and the same environments play a role for men and for women. The possibility that genetic influences may differ for men and for women is supported by a meta-analysis that indicated moderation of the effect of the apolipoprotein E gene by sex on risk of AD.¹⁷

In this article, we use biometrical twin analyses to address the following: (1) to verify in a population-based twin registry the extent of heritability of AD, (2) to evaluate possible differences between men and women in heritability of AD, and (3) to examine similarity between members of MZ vs DZ twin pairs in their age at onset of dementia.

METHODS

PARTICIPANTS

Swedish Twin Registry

The compilation of the Swedish Twin Registry is described in detail elsewhere.¹⁸ In 1961, a questionnaire was sent to all like-sex twin pairs born between 1886 and 1925 in which both twins were alive, with twin births having been identified from parish records. Unlike-sex pairs were not included in the questionnaire; however, using the stored parish records, pairs born between 1906 and 1925 have now been added to the computerized twin registry. In 1970, the cohort of twins born between 1926 and 1967 was identified using the nationalized birth registration system then in place, and in 1973, like-sex twins in the new cohort were sent a questionnaire. The registry is regularly matched to other national health care registries to update address and vital status information. No contact with the entire registry took place for the next 25 years. In 1998-2001, all living twins in the twin registry who were born in 1935 and earlier, both like- and unlike-sex twins, were requested to participate in a telephone screening interview. This interview included screening for cognitive dysfunction to identify potential cases for a study of dementia. If the twin were unable to be interviewed, a brief interview that included questions about cognitive status was carried out with an informant. The study of dementia in Swedish twins is known as HARMONY.

HARMONY Sample

We have recently presented detailed information about case identification for HARMONY.¹⁹ A 2-phase procedure was followed, with a screening phase and a clinical phase. Individual participation rate was 71.5% for the screening phase and 69.7% for the clinical phase.

The data set for the analyses presented here includes all pairs where one or both members of the pair participated in either phase. After excluding 131 pairs where zygosity was indeterminate, the total number of pairs was 11 884 (10% MZ male, 14% MZ female, 18% DZ male, 26% DZ female, and 32% unlike-sex pairs). For 127 individuals whose twin partner was dead and hence did not participate in the first phase, information was available from medical records and informants or from pilot work with subsamples of the twin registry, enabling the diagnostic board to ascertain dementia status so that the pair data could be complete. Sample size for complete pairs and for individuals from complete and incomplete pairs, by sex and zygosity, appears in **Table 1**.

Individuals were classified as demented based on clinical diagnoses or as nondemented if either the clinical evaluation determined that the individual did not meet diagnostic criteria for dementia or if the individual screened negative. The resulting data set included 680 individuals with a diagnosis of dementia and 12 546 individuals who were nondemented. Among those with dementia were 428 with probable or possible AD; 168 with vascular dementia or mixed AD and vascular dementia; 31 with dementia secondary to another medical condition; and 53 other or type not specified. The total number of pairs where one or both had AD was 392. For analyses of AD, individuals with a different type of dementia were treated as missing. Average age at onset of dementia is listed in Table 1.

PROCEDURES

The screening phase was conducted by telephone and was designed to identify anyone with cognitive dysfunction using a screening tool with high sensitivity so that false negatives would be minimized. For the twins themselves, telephone cognitive screening used the TELE questionnaire.²⁰ Informants were given the Blessed Dementia Rating Scale.²¹ The TELE has been demonstrated to have a sensitivity of 0.95 in an unselected community sample, with specificity set low (0.52) to minimize false negatives,²² and to perform well relative to other telephone screening protocols.²³

The clinical phase entailed complete in-person diagnostic evaluations for dementia for individuals who screened positive, their co-twins, and a sample of twins where both had screened negative. Clinical diagnoses used information collected by an assessment team comprising a physician and a nurse. Assessments included neuropsychological testing, a semistructured interview with a knowledgeable informant, and a physical examination with blood panel. A diagnostic review board took the assessment information and independently formulated a clinical dementia diagnosis and differential diagnosis of type of dementia, following *Diagnostic and Statistical Manual of Mental Disorders, Fourth Edition (DSM-IV)* criteria for dementia,²⁴ NINCDS/ADRDA criteria (National Institute of Neurological and Communicative Disorders and Stroke-Alzheimer's Disease and Related Disorders Association) for AD,²⁵ NINDS-AIREN criteria (Neuroepidemiology Branch of the National Institute of Neurological Disorders and Stroke-Association Internationale pour la Recherche et l'Enseignement en Neurosciences) for vascular dementia,²⁶ Lund and Manchester criteria for frontal temporal dementia,²⁷ and consensus criteria for dementia with Lewy bodies.²⁸ Individuals were first classified as demented, questionable (meeting some but not all DSM-IV criteria), or nondemented and then given a differen-

Table 1. Prevalence of Total Dementia and Alzheimer Disease, Probandwise Concordance Rates, and Tetrachoric Correlations (With 95% Confidence Intervals) by Zygosity and Sex

	MZ Men	MZ Women	DZ Men	DZ Women	Unlike-Sex Twins	
Complete pairs, No.*	428	655	679	1009	1454	
Individuals, No.	1355	1884	2333	3247	Men 2121	Women 2286
Prevalence						
Total dementia, No., %†	68 (5.02)	143 (7.59)	94 (4.03)	245 (7.55)	60 (2.83)	70 (3.06)
AD, %‡	2.65	5.74	2.44	5.03	1.25	1.99
Age at onset of dementia, mean ± SD, y	76.6 ± 7.1	78.2 ± 7.6	75.1 ± 9.2	79.0 ± 7.8	76.2 ± 7.2	74.6 ± 7.5
Probandwise concordance, %						
Total dementia	44	58	25	45	26	
AD	45	61	19	41	21	
Tetrachoric correlation (95% CI)						
Total dementia	0.73 (0.52-0.87)	0.83 (0.72-0.90)	0.53 (0.29-0.73)	0.70 (0.59-0.79)	0.63 (0.46-0.76)	
AD	0.81 (0.72-0.94)	0.89 (0.78-0.95)	0.48 (0.14-0.73)	0.76 (0.66-0.86)	0.58 (0.33-0.77)	

Abbreviations: AD, Alzheimer disease; CI, confidence interval; DZ, dizygotic; MZ, monozygotic.

*Complete pairs are those in which both members of the pair participated.

†Prevalence of dementia calculated as number of cases divided by number of individuals.

‡Prevalence of Alzheimer disease calculated after removing other cases of dementia from the denominator.

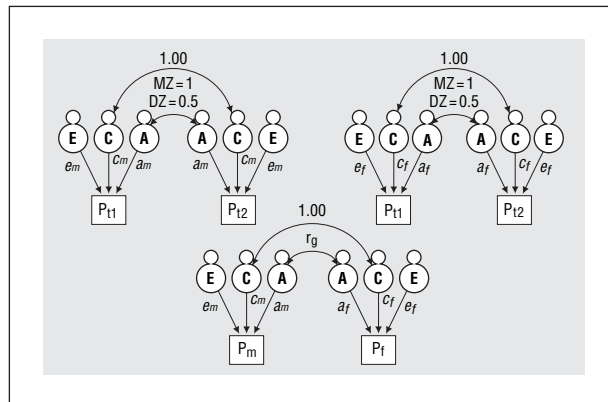

Figure 1. Model of sex limitation of genetic effects. A indicates genetic influences; a, genetic loadings; C, shared environmental influences; c, shared environmental loadings; DZ, dizygotic; E, nonshared environmental influences; e, nonshared environmental loadings; f, female; m, male; MZ, monozygotic; P₁₁, twin 1's phenotype; P₁₂, twin 2's phenotype; r_g, genetic correlation. The 1.00, 1, and 0.5 notations represent the assumptions of the twin model that the correlation of additive genetic components is 1 for monozygotic twins and 0.5 for dizygotic twins and that the correlation of shared factors is 1.00 for both twin types.

tial diagnosis for type of dementia. For purposes of analysis, those who were questionable (that is, possibly prodromal) were included with those who were nondemented. Weighted κ for agreement between the 2 members of the diagnostic review board on DSM-IV diagnoses was 0.86 for 204 individuals.

Age at onset was established by the assessment team when it met to reach initial conclusions about the case. Information used to determine age at onset included a detailed informant interview to ascertain when different symptoms first occurred and how they interfered with the twin's life, as well as reading medical records for mention of problems with memory or thinking or a formal dementia diagnosis. Age at onset was defined as the age at which definite and enduring symptoms of dementia first appeared.

STATISTICAL ANALYSIS

Descriptive data analyses included those for prevalence rate for cases, probandwise concordance, and tetrachoric correlations

within each of the 5 groups. Probandwise concordance is the ratio of the number of affected twin partners of independently ascertained cases to the total number of cases.²⁹ Tetrachoric correlations represent the correlation of liability for the disorder between twins in a pair. For AD, individuals with other dementias were excluded from the analyses. Results for total dementia include all dementias. Pairs were included if either member of the pair was in the HARMONY sample.

Biometrical twin analyses were conducted on raw ordinal data using the Mx data program (Department of Psychiatry, Virginia Commonwealth University, Richmond, Va)³⁰ in which twin resemblance was compared for 5 groups of twins: male and female MZ and DZ twins as well as unlike-sex pairs. In ordinal models, each individual is coded as having the disease or not having the disease, and the threshold is the z score that corresponds to the rate of the disease. Thus, the model assumes an underlying normally distributed liability. Using the raw data option in Mx permits including incomplete pairs who contributed information for the estimation of thresholds but not for twin resemblance. Model fitting used the method of maximum likelihood.

The sex-limitation twin model is shown in **Figure 1**. Variance is partitioned into 3 components: A (additive genetic), C (shared environmental effects common to both members of a twin pair), and E (nonshared or unique environmental effects). The observed data are fit based on assuming that genetic similarity is half as great for DZ as for MZ twin pairs, ie, 0.5 vs 1.0, while environmental influences shared by twins in a pair contribute equally to making MZ and DZ pairs similar and are correlated 1.0. Unlike-sex twins contribute to resolving whether sex limitation is present, ie, whether different genes may be influential for men and women.³¹ As indicated in Figure 1, if different genetic influences are important for the disease in men and in women, then unlike-sex twins will be less genetically similar for the trait than DZ twins, and the genetic correlation (r_g) will be less than 0.5. Alternatively, if different environments are more influential in one sex than the other, then one can test whether the correlation between environments shared by twins (r_c) is less than 1.0 in unlike-sex pairs. If neither were supported, one can test whether the magnitudes of genetic and environmental sources of variance differed significantly by sex comparing the fit of the 5-group unconstrained model with a model where genetic and

environmental influences were set to be the same for men and women. In addition, a series of models were tested, successively dropping either the A or the C parameter. Alternative nested models were compared by taking the difference in log likelihood between the full and reduced model, which is distributed as a χ^2 with degrees of freedom equal to the difference in the number of parameters estimated in each model.

Finally, with an age-related disease, twin similarity for age is confounded with twin similarity for disease. This leads to inflation of C. Therefore, we adjusted the estimated thresholds (ie, rate of the disease) according to age of the twin. The adjustment is expressed as β_{age} .¹⁴

Comparison of ages at onset within concordant MZ and DZ twin pairs relied on a Wilcoxon 2-sample test. This statistic reduces the effect of isolated extreme scores when data are not normally distributed.

RESULTS

Sample sizes, unadjusted prevalence rates, proband-wise concordance rates, and tetrachoric correlations are listed in Table 1 for both AD and total dementia for all 5 groups. Prevalence tended to be higher for women than for men, and rates of disease were higher among those who were older than those who were younger (**Figure 2**). As shown by both concordance rates and tetrachoric correlations, resemblance was greater for MZ than for DZ and for women than for men. Concordance for vascular dementia (not listed in the table) was very low, with only 1 MZ pair, 3 DZ pairs, and 3 unlike-sex pairs in which both twins had vascular dementia or mixed vascular and AD.

Model-fitting results for AD are summarized in **Table 2**. Findings for total dementia were similar and are therefore not shown. The top section of Table 2 provides results of the 5-group model without including β_{age} . These results are included because the method corresponds to how other twin studies have calculated heritability. Thresholds could be equated for twins in a pair, in MZ and DZ men, and for MZ and DZ women, but not for men and women and not for like-sex and unlike-sex pairs. Therefore, thresholds were allowed to differ for men and women in like-sex pairs and for unlike-sex pairs. In the results presented in Table 2, the amount of variance assigned to C is substantial, especially for women.

The bottom sections of Table 2 list results of the 5-group model with age-adjusted thresholds. With β_{age} in the model and allowed to differ for men and women, sex differences in thresholds were no longer significant, indicating that the differences in thresholds likely reflected the greater longevity of women compared with men and hence their greater opportunity to have become demented. Although allowed freely to vary, the genetic correlation (r_g) for unlike-sex pairs was estimated to be 0.5, providing no evidence that different sets of genes are important for men and women. Similarly, the correlation between environments shared by twins (r_c) was not significantly less than 1.0 in unlike-sex pairs, providing no evidence for sex differences in the nature of shared environmental factors.

The lower threshold for unlike-sex pairs may reflect the historical difference in how unlike-sex pairs were enrolled in the twin registry, in which those born the ear-

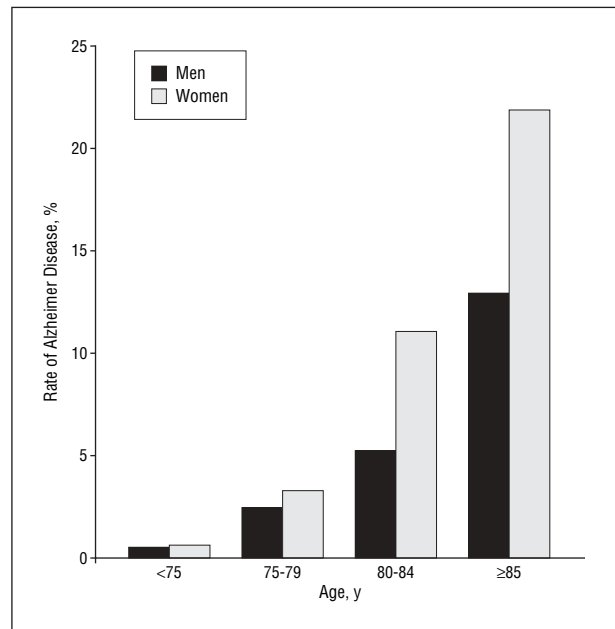

Figure 2. Prevalence of Alzheimer disease by age group and sex.

liest may have been lost to enrollment in the twin registry. Accordingly, we also examined a 4-group model that excluded the unlike-sex pairs and compared those estimates with the corresponding estimates from the 5-group model. Estimates for A, C, and E were essentially the same as in the 5-group model.

In the model fitting when full and reduced models were compared, it was possible to set the shared environment parameter to 0 for men and women ($P = .34$ and $.09$, respectively). For men, it was possible to drop either the additive genetic effect ($P = .12$) or the shared environmental effect ($P = .34$), but not both ($P < .001$). However, for women, dropping the additive genetic effect resulted in a significant loss of fit ($P = .04$).

Although the parameter estimates for men and women appeared to be quite different, the difference χ^2 was not significant for comparing the full model with different parameters for men and women with the model with men and women equated ($P = .36$). After men and women were equated, setting the shared environmental parameter to 0 resulted in no significant loss of fit ($P = .35$). This best-fitting reduced model, where estimates are equated for men and women and the C parameter is dropped, is presented in the last row of Table 2.

We evaluated the effect of our methodological choices by comparing concordance rates and models that would have resulted from alternative decisions. If pairs were included in the AD analyses when one twin had AD while the twin partner had another dementia, concordance in all groups increased only slightly. If pairs were included only when both members of the pair were alive for the screening phase, DZ concordance decreased slightly and estimates of the C parameter showed a small increase, slightly more so for men than for women.

Average age at onset for AD among all MZ individuals was 78.1 years; likewise, average age at onset among all DZ individuals was 78.1 years. Among 25 MZ pairs where both had AD, the average \pm SD differ-

Table 2. Parameter Estimates (With 95% Confidence Intervals) From Model Fitting Results for Alzheimer Disease: Full Model Without Adjusting for Age and Full and Reduced Models Adjusting for Age*

Group	A*	C*	E*	r_g for Unlike-Sex Pairs	Threshold†
Full Model Without Adjusting for Age					
Men	0.59 (0.00-0.89)	0.21 (0.00-0.72)	0.20 (0.07-0.46)		1.96
Women	0.37 (0.11-0.63)	0.53 (0.29-0.73)	0.10 (0.05-0.20)		1.47
Unlike sex				0.50	2.14
Full Model Adjusting for Age					
	A*	C*	E*	r_g for Unlike-Sex Pairs	β_{age}
Men	0.58 (0.00-0.86)	0.07 (0.00-0.59)	0.36 (0.14-0.69)		-0.08
Women	0.45 (0.02-0.88)	0.36 (0.00-0.71)	0.19 (0.09-0.35)	0.50	-0.09
Reduced Models Adjusting for Age					
Men and women equated	0.58 (0.19-0.87)	0.19 (0.00-0.49)	0.23 (0.13-0.37)	0.50	-0.09
Men and women equated, C parameter dropped	0.79 (0.67-0.88)	NA	0.21 (0.12-0.33)	0.50	-0.09

Abbreviations: A, additive genetic influences; β_{age} , regression coefficient for age; C, shared environmental influences; E, nonshared environmental influences; NA, not applicable; r_g , genetic correlation.

*All values are parameter estimate (confidence interval).

†Threshold is the z score corresponding to prevalence.

ence in age at onset was 3.66 ± 3.63 years. Among 20 DZ pairs where both had AD, the average \pm SD difference in age at onset was 8.12 ± 7.04 years. A Wilcoxon 2-sample test normal approximation resulted in a z score of 2.73, which corresponds to a 1-sided probability of .003. There was no relationship between the intrapair difference in age at onset and the age at which the first twin became affected.

COMMENT

In the largest population-based twin study of dementia to date, with like- and unlike-sex pairs and using advancements in twin methodology, we have confirmed that heritability of AD is high and does not differ by sex. The same genetic effects are operating in men and women. Genes also seem to have a role in disease timing because age at onset of AD is significantly more similar for concordant MZ pairs compared with concordant DZ pairs. These results are based on a large sample, using clinical diagnoses.

Prior studies—characterized by smaller samples, selective samples, or diagnoses based on registry information—have found diverse heritability estimates, some similar to as well as some lower than those in the present study. The earliest twin study used the New York State Psychiatric Institute Study of Aging Twins. Diagnostic criteria for AD now in use were not then available; rather they relied on diagnoses of “senile dementia” to examine concordance rates in 54 pairs.⁸ Their concordance rate for MZ was 43%, which is similar to our findings for total dementia, but their concordance rate for DZ was 8%, which is considerably lower than what we observed.

Since the New York State Psychiatric Institute study, there have been both US and Nordic twin studies of AD. The NAS-NRC (National Academy of Sciences–National Research Council) Twin Registry in the United States³² includes white men born in 1917 through 1927 where both members of the pair served in the Armed Forces. When these twins were aged

63 to 73 years, they were screened for AD.⁹ Possibly because the sample was relatively young, concordance rates based on 38 cases tended to be low relative to the present study and to other twin studies: 21% for MZ and 11% for DZ. The Norwegian Twin Registry (with both like- and unlike-sex pairs) was matched with lists of residents of long-term care facilities, and all potential cases were clinically evaluated; 72 twins with dementia (38 with AD) were identified.¹¹ A potential limitation of this approach is that those not in long-term care could have been missed. Concordance rates were higher in this study than in other studies: 83% for MZ and 46% for DZ. Heritability was estimated to be 58% while estimated shared environmental influences were 39%.

The Finnish Twin Registry, consisting of like-sex pairs born before 1958 where both co-twins were alive in 1975,³³ was linked with a registry containing hospital discharge diagnoses to identify twins with an *International Classification of Diseases, Ninth Revision (ICD-9)* diagnosis of dementia.³⁴ Diagnoses for 178 cases of dementia (94 with AD) were confirmed by medical record review.¹⁰ This analysis differs from the other twin studies in using a cohort design that included all cases, regardless of whether they were still living at the time of the study and whether or not they had been personally examined by the investigators. Because it relied on diagnoses written in medical records by physicians, cases of dementia may have been missed.³⁵ The concordance rates for AD reported for the Finnish Twin Registry are 31% for MZ and 9% for DZ. The low concordance rates compared with most other studies could reflect differences in a cohort compared with a cross-sectional design, underascertainment, biased ascertainment, or a combination of these factors. Prevalence of AD was higher for MZ than for DZ twins, which has not been confirmed by other reports.

A subsample of the Swedish Twin Registry based on the SATSA (Swedish Adoption/Twin Study of Aging) study has previously been ascertained for dementia.¹² Screening located 78 individuals with dementia (38 with AD). Heritability was estimated to be 74%, which is similar to

results from the best-fitting model in the present study. As was also reported by the Norwegian study, substantial influence from shared environmental factors was suggested (24%). Findings for the shared environmental factors illustrate how, if a disorder is age-related, that parameter may be overestimated. In the present study, controlling for age reduced the magnitude of the shared environment parameter.

Both the SATSA subsample and a second subsample from the OCTO (Octogenarian)-Twin study were able to be followed longitudinally, and those findings have been previously reported.³⁶ Individuals who were nondemented at baseline were ascertained again for dementia at follow-up. Results based on 77 incident cases of AD, with no correction for age, found somewhat lower heritability compared with estimates based on prevalent disease (48%) and no influence from shared environment. The reason that results for the analyses of incident cases showed lower heritability than results for analyses of prevalent cases reflects essential differences between the 2 designs; namely, for the incident design, the cases include only those who developed dementia over a 5-year period. If the incident sample were followed longer, more cases of dementia and more concordant pairs would be likely. Finally, in contrast to the present study, none of the previous reports based on the Swedish Twin Registry represent comprehensive ascertainment of the whole registry nor do they include unlike-sex pairs.

Previous twin studies of AD have not been able to evaluate sex differences. In the present analyses, we found that more women than men in the population had AD; however, women and men did not differ in prevalence once age was taken into account. Concordance was higher in women, reflecting their greater longevity. For these reasons, the shared environment parameter was larger for women than for men, especially in models that did not take age into account. There was no significant moderation of genetic effects by sex. With age taken into account, models for men and women could be equated. For this latter reason, the apparent difference in shared environmental effects for women and men after controlling for age should not be overinterpreted. Nonetheless, it is possible that female siblings might be more similar in their environments than male siblings. Previous analyses with the SATSA sample from the Swedish Twin Registry also found influences for shared environment for Mini-Mental State Examination scores for women but not for men.³⁷

The most important differences between past twin studies and the present report are (1) the size of the study, in which the number of cases is from 4-fold to more than 10-fold greater than those reported earlier; (2) representativeness of the sample; (3) inclusion of unlike-sex pairs to test for evidence of sex limitation; and (4) incorporation of an age correction to the disease threshold in the biometrical twin models that statistically controls for spurious twin resemblance because of their shared age.

The present study also has a number of limitations, including the following:

- This is a prevalence study, and it is not possible to distinguish whether discordant twin pairs will ultimately

differ in presence of disease or whether they are only different in age at onset. In evaluating genetic variability for having AD, influences related to age at onset are included, and it is not possible to separate susceptibility to AD from age at onset for AD. Ideally, all of these twins could be followed up longitudinally. Nonetheless, the range of ages included in the present study ensures that the sample was not limited to individuals too young to be at risk for developing dementia. Still, more definitive results will only become available as repeated examinations are undertaken of this and other twin registries.

- Not all twins agreed to participate, with refusal both at screening and clinical phases. We have previously noted that prevalence of dementia in the present study was comparable with several major epidemiological studies of dementia prevalence.^{38,39} To test how nonparticipation might be affecting the results, we used information available in the twin registry from linking to the national Inpatient Discharge Registry and Cause of Death Registry, which contain diagnoses for hospital stays and causes of death, respectively, recorded using the ICD revision current at the time of the event. Thus, we determined whether nonparticipants had any dementia diagnosis recorded. When we added this information to our data, the analyses showed that heritability of dementia was within 1% for men and 2% for women, compared with the results based only on cases identified by our protocol.

- In twin studies, estimates of the influence of genes and environment are relative. When variation due to environmental factors is low, estimates of the role of genetic effects will be higher. Moreover, both sets of influences are “anonymous”; that is, we cannot use the results to infer what genes may be involved or what environmental factors might be important.

The results of the present study also provide important evidence for the extent to which environment influences disease occurrence. Concordance is not perfect, there is important influence due to nonshared environment, and age at onset in concordant pairs varies, all suggesting that there are nongenetic lifestyle factors that can affect the risk and timing of AD.

Submitted for Publication: December 8, 2004; final revision received April 29, 2005; accepted August 18, 2005.

Author Affiliations: Department of Psychology, University of Southern California, Los Angeles (Drs Gatz, Fiske, and Pedersen); Department of Medical Epidemiology and Biostatistics (Drs Gatz and Pedersen) and Aging Research Center (Dr Fratiglioni), Karolinska Institutet, Stockholm, Sweden; Department of Psychology, University of California at Riverside (Dr Reynolds); Department of Psychology, Göteborg University, Göteborg, Sweden (Dr Johansson); Department of Epidemiology and Biostatistics, University of South Florida, Tampa (Dr Mortimer); Institute of Gerontology, School of Health Sciences, Jönköping University, Jönköping, Sweden (Dr Berg); and Department of Psychology, West Virginia University, Morgantown (Dr Fiske).

Correspondence: Margaret Gatz, PhD, Department of Psychology, University of Southern California, 3620 McClintock Ave, Los Angeles, CA 90089-1061 (gatz@usc.edu).

Funding/Support: This work was supported by grant R01-AG08724 from the National Institute on Aging, Bethesda, Md. Dr Gatz held a Zenith Award (ZEN-02-3895) from the Alzheimer's Association, Chicago, Ill.

Acknowledgment: The name HARMONY comes from the Swedish words for "health" (*hälsa*), "genes" (*arv*), "environment" (*miljö*), "and" (*och*), and "new" (*ny*). We thank Charles O. Gardner for making available his Mx script for incorporating age thresholds into an ordinal model. All protocols are available online at <http://www.usc.edu/dept/LAS/psychology/SCRAP>. Age-at-onset questions are shown in the protocol named Debut.

REFERENCES

- Hendrie HC. Epidemiology of dementia and Alzheimer's disease. *Am J Geriatr Psychiatry*. 1998;6:S3-S18.
- Brookmeyer R, Gray S, Kawas C. Projections of Alzheimer's disease in the United States and the public health impact of delaying disease onset. *Am J Public Health*. 1998;88:1337-1342.
- Bird T. Genetic factors in Alzheimer's disease. *N Engl J Med*. 2005;352:862-864.
- Kumar A, Schapiro MB, Grady CL, Matocha MF, Haxby JV, Moore AM, Luxenberg JS, St George-Hyslop PH, Robinette CD, Ball MJ, Rapoport SI. Anatomic, metabolic, neuropsychological, and molecular genetic studies of three pairs of identical twins discordant for dementia of the Alzheimer's type. *Arch Neurol*. 1991;48:160-168.
- Small GW, Leuchter AF, Mandelkern MA, La Rue A, Okonek A, Lufkin RB, Jarvik LF, Matsuyama SS, Bondareff W. Clinical, neuroimaging, and environmental risk differences in monozygotic female twins appearing discordant for dementia of the Alzheimer type. *Arch Neurol*. 1993;50:209-219.
- Järvenpää T, Riihää I, Kaprio J, Koskenvuo M, Laine M, Kurki T, Viljanen T, Rinne JO. A 90-year-old monozygotic female twin pair discordant for Alzheimer's disease. *Neurobiol Aging*. 2003;24:941-945.
- Squitti R, Cassetta E, Dal Forno G, Lupoi D, Lippolis G, Pauri F, Vernieri F, Cappa A, Rossini PM. Copper perturbation in 2 monozygotic twins discordant for degree of cognitive impairment. *Arch Neurol*. 2004;61:738-743.
- Kallman FJ. Genetic aspects of mental disorders in later life. In: Kaplan OJ, ed. *Mental Disorders in Later Life*, Second edition. Stanford, Calif: Stanford University Press; 1956:26-46.
- Breitner JCS, Welsh KA, Gau BA, McDonald WM, Steffens CD, Saunders AM, Magruder KM, Helms MJ, Plassman BL, Folstein MF, Brandt J, Robinette CD, Page WF. Alzheimer's disease in the National Academy of Sciences-National Research Council registry of aging twin veterans. III. Detection of cases, longitudinal results, and observations on twin concordance. *Arch Neurol*. 1995;52:763-771.
- Riihää I, Kaprio J, Koskenvuo M, Rajala T, Sourander L. Alzheimer's disease in Finnish twins. *Lancet*. 1996;347:573-578.
- Bergem AL, Engedal K, Kringlen E. The role of heredity in late-onset Alzheimer disease and vascular dementia: a twin study. *Arch Gen Psychiatry*. 1997;54:264-270.
- Gatz M, Pedersen NL, Berg S, Johansson B, Johansson K, Mortimer JA, Posner SF, Viitanen M, Winblad B, Ahlborn A. Heritability for Alzheimer's disease: the study of dementia in Swedish twins. *J Gerontol A Biol Sci Med Sci*. 1997;52:M117-M125.
- Plassman BL, Steffens DC, Burke JR, Welsh-Bohmer KA, Helms MJ. Alzheimer's disease in the NAS-NRC Twin Registry of WWII Veterans [abstract]. *Neurobiol Aging*. 2004;25(suppl 2):514.
- Reynolds CA, Fiske A, Fratiglioni L, Pedersen N, Gatz M. Heritability of an age-dependent categorical phenotype: cognitive dysfunction. *Twin Res Hum Genet*. In press.
- Steffens DC, Plassman BL, Helms MJ, Welsh-Bohmer KA, Saunders AM, Breitner JCS. A twin study of late-onset depression and apolipoprotein E epsilon 4 as risk factors for Alzheimer's disease. *Biol Psychiatry*. 1997;41:851-856.
- McGue M, Bouchard TJ Jr. Adjustment of twin data for the effects of age and sex. *Behav Genet*. 1984;14:325-343.
- Farrer LA, Cupples LA, Haines JL, Hyman B, Kukull WA, Mayeux R, Myers RH, Pericak-Vance MA, Risch N, van Duijn CM. Effects of age, sex, and ethnicity on the association between apolipoprotein E genotype and Alzheimer's disease: a meta-analysis. APOE and Alzheimer Disease Meta Analysis Consortium. *JAMA*. 1997;278:1349-1356.
- Lichtenstein P, de Faire U, Floderus B, Svartengren M, Svedberg P, Pedersen NL. The Swedish Twin Registry: a unique resource for clinical, epidemiological, and genetic studies. *J Intern Med*. 2002;252:184-205.
- Gatz M, Fratiglioni L, Johansson B, Berg S, Mortimer JA, Reynolds CA, Fiske A, Pedersen NL. Complete ascertainment of dementia in the Swedish Twin Registry: the HARMONY study. *Neurobiol Aging*. 2005;26:439-447.
- Gatz M, Reynolds C, Nikolic J, Lowe B, Karel M, Pedersen NL. An empirical test of telephone screening to identify potential dementia cases. *Int Psychogeriatr*. 1995;7:429-438.
- Erkinjuntti T, Hokkanen L, Sulkava R, Palo J. The Blessed Dementia Scale as a screening test for dementia. *Int J Geriatr Psychiatry*. 1988;3:267-273.
- Gatz M, Reynolds CA, John R, Johansson B, Mortimer JA, Pedersen NL. Telephone screening to identify potential dementia cases in a population-based sample of older adults. *Int Psychogeriatr*. 2002;14:273-289.
- Järvenpää T, Rinne JO, Riihää I, Koskenvuo M, Loppinen M, Hinkka S, Kaprio J. Characteristics of two telephone screens for cognitive impairment. *Dement Geriatr Cogn Disord*. 2002;13:149-155.
- American Psychiatric Association. *Diagnostic and Statistical Manual of Mental Disorders, Fourth Edition, Text Revision*. Washington, DC: American Psychiatric Association; 2000.
- McKhann G, Drachman D, Folstein M, Katzman R, Price D, Stadlan EM. Clinical diagnosis of Alzheimer's disease: report of the NINCDS-ADRDA Work Group under the auspices of Department of Health and Human Services Task Force on Alzheimer's Disease. *Neurology*. 1984;34:939-944.
- Roman GC, Tatemichi TK, Erkinjuntti T, Cummings JL, Masdeu JC, Garcia JH, Amaducci L, Orgogozo JM, Brun A, Hofman A. Vascular dementia: diagnostic criteria for research studies. Report of the NINDS-AIREN International Workshop. *Neurology*. 1993;43:250-260.
- Lund and Manchester Groups. Clinical and neuropathological criteria for frontotemporal dementia. *J Neurol Neurosurg Psychiatry*. 1994;57:416-418.
- McKeith IG, Galasko D, Kosaka K, Perry EK, Dickson DW, Hansen LA, Salmon DP, Lowe J, Mirra SS, Byrne EJ, Lennox G, Quinn NP, Edwardson JA, Ince PG, Bergeron C, Burns A, Miller BL, Lovestone S, Collerton D, Jansen EN, Ballard C, de Vos RA, Wilcock GK, Jellinger KA, Perry RH. Consensus guidelines for the clinical and pathologic diagnosis of dementia with Lewy bodies (DLB): report of the consortium on DLB international workshop. *Neurology*. 1996;47:1113-1124.
- McGue M. When assessing twin concordance, use the probandwise not the pairwise rate. *Schizophr Bull*. 1992;18:171-176.
- Neale MC, Boker SM, Xie G, Maes HH. *Mx: Statistical Modeling*, Fifth Edition. Richmond, Va: Department of Psychiatry, Virginia Commonwealth University; 1999.
- Reynolds CA, Hewitt JK. Issues in the behavior genetic investigation of gender differences. In: Turner JR, Cardon LR, Hewitt JK, eds. *Behavior Genetic Approaches in Behavioral Medicine*. New York, NY: Plenum Press, 1995.
- Page WF. The NAS-NRC Twin Registry of WWII military veteran twins. *Twin Res*. 2002;5:493-496.
- Kaprio J, Koskenvuo M. Genetic and environmental factors in complex diseases: the older Finnish twin cohort. *Twin Res*. 2002;5:358-365.
- World Health Organization. *International Classification of Diseases, Ninth Revision (ICD-9)*. Geneva, Switzerland: World Health Organization; 1977.
- Callahan CM, Hendrie HC, Tierney WM. Documentation and evaluation of cognitive impairment in elderly primary care patients. *Ann Intern Med*. 1995;122:422-429.
- Pedersen NL, Gatz M, Berg S, Johansson B. How heritable is Alzheimer disease late in life? Findings from Swedish twins. *Ann Neurol*. 2004;55:180-185.
- Pedersen NL, Reynolds CA, Gatz M. Sources of covariation among Mini-Mental State Examination scores, education, and cognitive abilities. *J Gerontol B Psychol Sci Soc Sci*. 1996;51:P55-P63.
- Fratiglioni L, Grut M, Forsell Y, Viitanen M, Grafström M, Holmen K, Ericsson K, Backman L, Ahlborn A, Winblad B. Prevalence of Alzheimer's disease and other dementias in an elderly urban population: relationship with age, sex, and education. *Neurology*. 1991;41:1886-1892.
- Bachman DL, Wolf PA, Linn R, Knoefel JE, Cobb J, Belanger A, D'Agostino RB, White LR. Prevalence of dementia and probable senile dementia of the Alzheimer type in the Framingham Study. *Neurology*. 1992;42:115-119.