

The Effects of Seasons and Light Therapy on G Protein Levels in Mononuclear Leukocytes of Patients With Seasonal Affective Disorder

Sofia Avissar, PhD; Gabriel Schreiber, MD, PhD; Yakov Nechamkin, MD; Isaac Neuhaus, BA; Gregory K. Lam, BS; Paul Schwartz, MD; Erick Turner, MD; Jeffery Matthews, MD; Susana Naim, MD; Norman E. Rosenthal, MD

Background: Information-transducing heterotrimeric G proteins have been implicated previously in the mechanism of action of mood stabilizers and in the pathophysiology of mood disorders. Mononuclear leukocytes of patients with unipolar and bipolar depression have been characterized by reduced measures of the stimulatory and inhibitory G proteins. In this study, patients with seasonal affective disorder (SAD) were measured for mononuclear leukocyte G protein levels while depressed during the winter, following light therapy, and in remission during the summer.

Methods: Twenty-six patients with SAD and 28 healthy subjects were assessed in the study. The immunoreactivities of $G_s\alpha$, $G_i\alpha$, and $G\beta$ subunit proteins were determined by Western blot analysis of mononuclear leukocyte membranes with selective polyclonal antibodies for the various G subunit proteins, followed by densitometric quantitation using an image analysis system.

Results: Untreated patients with SAD and winter, atypical-type depression showed significantly reduced mononuclear leukocyte immunoreactive levels of $G_s\alpha$ and $G_i\alpha$ proteins, similar to previous observations in patients with nonseasonal major depression. The reduced G protein levels were normalized with 2 weeks of light therapy. The same patients while in remission during the summer had G protein levels that were similar to those of healthy subjects.

Conclusions: G protein-immunoreactive measures in patients with SAD are suggested as a state marker for winter depression, which is normalized by light treatment and during the summer. We speculate that light may exert its effects via normalization of transducin (G_t protein) levels, which are thought to be reduced in winter depression.

Arch Gen Psychiatry. 1999;56:178-183

From the Departments of Clinical Pharmacology (Dr Avissar) and Psychiatry (Drs Schreiber and Nechamkin), Faculty for Health Sciences, Ben-Gurion University of the Negev, Beer Sheva, Israel (Drs Avissar, Schreiber, and Nechamkin); and Clinical Psychobiology Branch, National Institute of Mental Health, National Institutes of Health, Bethesda, Md (Messrs Neuhaus and Lam and Drs Schwartz, Turner, Matthews, Naim, and Rosenthal).

SEASONAL AFFECTIVE DISORDER (SAD) is a mood disorder characterized by recurrent episodes of winter depression, with remission or hypomanic periods in the spring and summer.¹ Patients with SAD differ from patients with melancholia in their clinical profiles (SAD patients overeat, crave carbohydrates, gain weight, sleep more, and are tired frequently), as well as in their biological characteristics (eg, normal dexamethasone suppression test responses, normal responses to thyrotropin-releasing hormone challenge tests, and normal rapid eye movement sleep latency), which resemble those of patients with atypical depression.¹ The efficacy of phototherapy for SAD has been generally acknowledged.^{2,3}

Although there is no consensus on the pathophysiology of SAD or on the mechanism of action of light therapy, the mechanisms that have been suggested to account for these phenomena generally involve altered primary messenger func-

tion: abnormal brain serotonergic transmission,⁴ reduced sympathetic system arousal,⁵ and underactive hypothalamic-pituitary-adrenal axis functioning.⁶

The family of heterotrimeric G proteins is a crucial point of convergence in the transmission of signals from a variety of primary messengers and their membrane receptors to a series of downstream cellular events, including intracellular second messenger effector enzymes and ionic channels^{7,8} (**Figure 1**). The increasing interest in the clinical perspective of altered G protein function has yielded important findings concerning the involvement of G proteins in the pathophysiology of mood disorders and in the biochemical mechanisms underlying the treatment of these disorders. We found that the function of receptor-coupled G proteins was altered by treatment with lithium⁹⁻¹⁵ and other antibipolar medications.¹³⁻¹⁵ Studies by other groups, generally in agreement with these results, implicate the involvement of G proteins in

SUBJECTS AND METHODS

SUBJECTS

Patients and controls were recruited through newspaper and radio advertisements in the Washington, DC, metropolitan area, by word of mouth, and through referrals from physicians, therapists, friends, or family. Twenty-six patients (18 women) met the following inclusion criteria: (1) Rosenthal et al¹ diagnostic criteria for SAD, a pattern of recurrent depressions, at least 1 of which met criteria for a major depressive episode, and at least 2 of which occurred in consecutive years; (2) a score of at least 15 on the Structured Interview Guide for the Hamilton Depression Rating Scale–Seasonal Affective Disorders Version (SIGH-SAD³³); (3) absence of any additional current Axis I disorders; (4) good physical health as determined by results of physical examination and routine blood work; and (5) no use of light therapy or medications for the current winter depression. The mean age of onset in cases where SAD could definitely be determined was 28 years. Thus, patients had SAD for an average of 13 years. Of the 26 patients, 17 (13 women) had unipolar and 9 (5 women) bipolar II characteristics. Twenty-eight healthy controls (20 women) were matched with patients on the basis of age, sex, body mass index (BMI or Quetelet index: calculated as weight in kilograms divided by the square of the height in meters),² menstrual phase, and birth control status for women (4 women). Controls were required to have no personal or family history of Axis I psychiatric disorder and to be physically healthy. There were no significant differences (control vs SAD) in age (mean age, 46 years; range, 26–51 years vs mean age, 41 years; range, 26–60 years) and BMI (25.9 ± 11.4 vs 26.4 ± 11.2). Patients and healthy subjects were free of psychotropic medications for 1 month prior to the study, free of nonpsychotropic medications for 2 weeks prior to the study, and were allowed no more than 2 caffeinated beverages per day for 2 weeks prior to the study.

STUDY DESIGN

Subjects were studied during the winter (mean date, February 26, 1996 ± 29 days vs mean date, February 26,

1996 ± 32 days) in an untreated condition. Nineteen of the 26 patients with SAD were studied again after 2 weeks of standard light therapy. Of the 7 patients who did not receive light therapy, 5 missed the appointment during which blood for the study was scheduled to be drawn. The other 2 patients had poor treatment compliance, so we did not include them (blood was not withdrawn a second time) because the data would have been misleading. The patients received light therapy (10 000 lux) from a light box, 60 cm × 60 cm (Sun-Box Co, Gaithersburg, Md). The distance from the center of patient's forehead to center of the box was 30.48 cm. Light therapy was administered at home for 45 minutes, twice per day, once between 6 and 9 AM, and once between 6 and 9 PM, as has previously been described by Terman et al.³⁴ The summer group of the same patients included 22 patients, as 4 could not be reached. Remission was defined as not meeting criteria for major depression plus having SIGH-SAD scores of less than 10. Nonresponders were defined as meeting criteria for major depression plus having SIGH-SAD scores of more than 15. The same group of healthy volunteers was studied twice: during winter (28 subjects) and during summer (25 subjects; 2 could not be reached and 1 dropped out). Healthy volunteers did not receive light treatment in this study. Patients and healthy volunteers participated in the summer portion of the study between May 28 and July 25, 1996. For each study, 30 mL of blood was drawn in the morning (between 7 and 9 AM) at the Clinical Center of the National Institutes of Health, Bethesda, Md. The SIGH-SAD ratings were administered within 1 day of drawing the blood. Written informed consent was obtained after the procedures had been fully explained to the patients and the healthy subjects.

Several MNL preparations that were shipped from the United States to Israel could not be analyzed owing to technical problems in their preparations. These samples were either substantially contaminated with other cellular elements so that a sufficient quantity of MNL membrane protein could not be achieved in the MNL membrane preparations, or they were nonhomogeneous, forming large and/or dense cellular aggregates that could not be used for our

Continued on next page

lithium's mechanism of action.^{16–22} Increased G protein measures were detected in mononuclear leukocytes (MNLs) of patients with mania^{23,24} and in postmortem cerebral cortices of bipolar patients.^{25–27} Reduced functional measures of G proteins were found in MNLs of patients with major depressive disorder.^{24,28–30} Although conflicting results were obtained concerning G protein immunoreactive levels in MNLs of patients with major depression,³¹ a larger study has detected reduced levels of G_sα and G_iα proteins in MNLs of depressed patients that correlated with the severity of depression and with reductions in the functional measures of these proteins.³⁰ Quantitative and functional measures of G proteins in human MNLs were found to be age independent.³²

This study attempts to characterize G protein levels in peripheral blood elements of patients with SAD by addressing the following questions: (1) Do reduced G protein levels, which are characteristic of MNLs of patients with nonseasonal, typical depression, also appear in pa-

tients with SAD, whose depressive symptoms are generally described as atypical? (2) Does light therapy, which is known to improve depressive symptoms in patients with SAD, normalize any alterations in MNL G protein levels detected in depressed patients with SAD? (3) Do any alterations in MNL G protein levels detected in depressed patients with SAD reflect trait or state characteristics? Toward this end, patients with SAD were followed up with measurement of MNL G protein levels while depressed during the winter months, following light therapy, and while in remission during the summer months.

RESULTS

There were no significant differences in G protein levels between winter and summer samples of the controls. Normalizing the winter samples as our comparison reference, the results show similar G_sα, G_iα, and Gβ immunoreactivities for the control subjects during winter and

assay. There was not enough MNL membrane protein for all G protein examinations in some subjects owing to the limited amount of blood that was drawn (30 mL), together with several preparations that resulted in a lower yield of MNLs in the Ficoll-Hypaque gradient (Pharmacia, Uppsala, Sweden). In these cases, MNL preparations were serially assigned only to part of the immunoreactive determinations of the G protein subunits. Thus, from 26 untreated patients with SAD and atypical winter depression, 21 were examined for $G_{s\alpha}$ and $G_{i\alpha}$ immunoreactivities, and 22 for $G\beta$ immunoreactivity. After 2 weeks of light therapy, 15 of the 19 patients were evaluated for $G_{s\alpha}$, 16 for $G_{i\alpha}$, and 19 for $G\beta$. Of the 22 patients with SAD examined in the summer, 17 were analyzed for $G_{s\alpha}$, 20 for $G_{i\alpha}$, and 20 for $G\beta$. In the winter group, 21 of 28 healthy volunteer subjects were assessed for $G_{s\alpha}$, 17 for $G_{i\alpha}$, and 15 for $G\beta$ immunoreactivities, while in the summer group of the same subjects, 19 of 25 were measured for $G_{s\alpha}$ and 18 for $G_{i\alpha}$ and $G\beta$.

The study was approved by the institutional review board of the National Institutes of Mental Health. All the clinical work and MNL preparation was conducted in Bethesda. Frozen shipped MNL membranes were prepared and measured for G proteins in Israel. Experimenters in Israel who determined protein concentrations of the samples, ran the samples electrophoretically, and conducted immunoblotting and densitometry were blind to the diagnoses and/or state of the subjects. Gel protocols were prepared in advance to include matched controls in each gel.

MNL Isolation

Mononuclear leukocytes were isolated from 30 mL of heparinized fresh blood, using Ficoll-Hypaque gradient. Cells were homogenized in 25-mmol/L Tris-hydrochloride, pH 7.4, and 1-mmol/L dithiothreitol. The homogenate was passed through 2 layers of cheesecloth to remove debris, and membranes were collected by further centrifugation at 18 000g for 10 minutes. Membranes were then suspended in homogenization buffer containing 1-mmol/L ethyleneglycotetraacetic acid and 30% sucrose wt/vol and frozen at -70°C until assayed. Aliquots were taken for protein concentration determination using the Bradford assay.

Immunoblot Analysis

On the day of assay, membranes were thawed, aliquots of 10 μg taken for protein separation by 10% sodium dodecyl sulfate polyacrylamide gel electrophoresis, and the resulting proteins transferred to nitrocellulose paper by use of an electroblotting apparatus. Blots were washed in Tris-buffered saline containing 3% polyoxyethylene-sorbitan monolaurate (TTBS), and blocked by incubation with 5% bovine serum albumin for 1 hour in Tris-buffered saline containing 0.1% polyoxyethylene-sorbitan monolaurate. After 2 washes in TTBS, blots were incubated overnight with each of the following antisera (Santa Cruz Biotechnology Inc, Santa Cruz, Calif) directed specifically against $G_{s\alpha}$, $G_{i\alpha}$, and $G\beta$ (all diluted 1:100), followed by subsequent incubation with goat antirabbit IgG labeled with horseradish peroxidase (Jackson ImmunoResearch Laboratories Inc, Westgrove, Pa). Immunoreactivity was detected with a Western blot detection system (Enhanced Chemiluminescence Western Blot Detection System; Amersham, Buckinghamshire, England) followed by exposure to film (Kodak X-Omat; Kodak, Rochester, NY).

Assay linearity ranged from 2.5 to 15 μg . Peak heights of immunoreactive bands were determined with an image analysis system and semiquantitative analysis was carried out. The optical density of the immunoreactive bands was normalized against 10- μg rat cortical membranes, run in each blot as a standard value. Although anti- $G_{s\alpha}$ detects both 52- and 45-kd $G_{s\alpha}$ species, only the 45-kd species is consistently detected in leukocytes, while rat cortex membranes predominantly show the 52-kd species. The other subunits assayed in leukocytes were found to migrate at the expected molecular weights similarly to those labeled in the rat cortex membranes.

Statistical Analysis

The Wilcoxon signed rank test was used for intrablot comparisons, which are singular matched comparisons within immunoblots, with an α level of significance of .05. For interblot average comparisons, the Mann-Whitney U test was used and was corrected for multiple comparisons by the Bonferroni adjustment, with α level of significance of .02.

summer: for $G_{s\alpha}$, (100.0% \pm 20.4%) vs (99.3% \pm 18.3%), 2-tailed Wilcoxon statistic (W) = 4, n = 19, P > .05; for $G_{i\alpha}$, (100.0% \pm 29.5%) vs (97.2% \pm 28.4%), W = 30, n = 17, not significant; for $G\beta$: (100.0% \pm 24.1%) vs (102% \pm 22.2%), W = -12, n = 15, not significant, Wilcoxon signed rank test).

Figure 2 shows that $G_{s\alpha}$ and $G_{i\alpha}$ immunoreactive levels in MNLs of patients with winter depression (71.9% \pm 22.4% and 79.5% \pm 23.2%, respectively), were significantly reduced in comparison with the respective levels in healthy subjects (100.0% \pm 15.8% and 100% \pm 7.2%), using both intrablot matched comparisons (for $G_{s\alpha}$: W = 195, n = 21, P < .01; for $G_{i\alpha}$: W = 221, n = 21, P < .01, Wilcoxon signed rank test) and interblot average comparisons (for $G_{s\alpha}$: the Mann-Whitney test statistic [U] = 379, t_{40} = 3.99, P < .01; for $G_{i\alpha}$: U = 274, t_{36} = 2.8, P < .01, Mann-Whitney test). In contrast, MNL $G\beta$ levels of depressed patients with SAD (100.6% \pm 16.6%) were similar to levels in healthy vol-

unteers (100.0% \pm 9.4%), as calculated using both interblot average comparison (U = 170, t_{35} = 0.15, not significant, Mann-Whitney test), and intrablot matched comparisons (W = 37, n = 22, not significant, Wilcoxon signed rank test).

Two weeks of light therapy resulted in clinical remission in patients with SAD with decreases in typical, atypical, and total SIGH-SAD scores (**Table**). After 2 weeks of light therapy, the reduced $G_{s\alpha}$ and $G_{i\alpha}$ levels in the depressed patients with SAD were significantly elevated to normal levels (for $G_{s\alpha}$: 95.7% \pm 24.2%, W = 85, n = 15, P < .02; for $G_{i\alpha}$: 103.4% \pm 23.6%, W = 90, n = 16, P < .02; Wilcoxon signed rank test), while $G\beta$ levels, (100.3% \pm 14.3%) remained similar to the control values obtained for depressed patients with SAD (W = 5, n = 18, not significant, Wilcoxon signed rank test) (Figure 2). The table shows that $G_{s\alpha}$ and $G_{i\alpha}$ protein normalization paralleled clinical remission in all treated patients as well as in the subgroups of responders and nonresponders.

During the summer, the SIGH-SAD scores show the patients with SAD to be in remission (Table), with levels of MNL $G_s\alpha$ ($102.3\% \pm 19.5\%$), $G_i\alpha$ ($102.9\% \pm 21.7\%$), and $G\beta$ ($101.5\% \pm 18.7\%$) similar to levels obtained for healthy subjects (for $G_s\alpha$: $U_s = 169$, $t_{34} = 0.24$, not sig-

nificant; for $G_i\alpha$: $U_s = 218$, $t_{36} = 1.11$, not significant; for $U_s = 170$, $t_{36} = 0.25$, Mann-Whitney test).

COMMENT

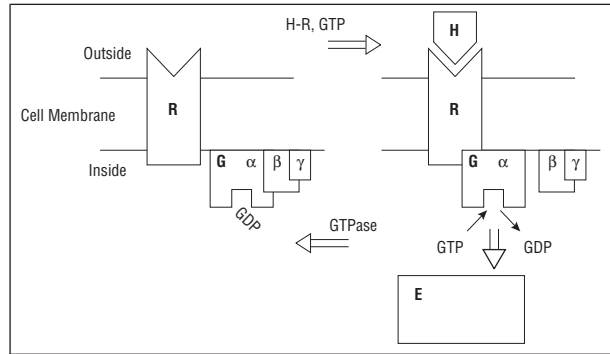

Figure 1. G protein as an information transducer from membrane receptor to intracellular effectors, the cycle of activation and inactivation. Heterotrimeric G proteins are located in the inner side of the cell membrane, playing a pivotal role in signal transduction beyond the receptor. The 3 G subunit proteins are α , β , γ . The α subunit contains the binding site for guanine nucleotides and possesses guanosine triphosphatase activity. The α subunit also contains the site for nicotinamide adenine nucleotide-dependent adenosine diphosphate-ribosylation catalyzed by cholera or pertussis bacterial toxins. The heterogeneity of α subunit serves to divide G proteins into the major classes (G_s , G_i , G_o , G_q , etc). The β and γ subunits, which have their functional roles in signal transduction, form a tightly associated complex, which contributes to the receptor recognition site on the G protein oligomer and facilitates the attachment of the oligomer to the inner face of the plasma membrane. When a hormone or a neurotransmitter (H) binds to its specific receptor (R), it forms an activated receptor-G protein (G) complex. This induces guanine nucleotide exchange on the α subunit of G protein so that guanosine diphosphate (GDP) is displaced by guanosine triphosphate (GTP). The binding of GTP induces the dissociation of the G protein. The GTP-bound α subunit interacts with the effector (E) molecule (ie, adenylate cyclase or phospholipases) and affects its activity in producing respective second messengers (ie, cyclic adenosine monophosphate, inositol triphosphate, diacylglycerol). The GTP-bound α subunit has also intrinsic guanosine diphosphatase (GTPase) activity. The α subunit is then left in an inactive form tightly bound to GDP, and the G protein subunits reassociate. The rate-limiting step in this cycle is the release of GDP from the α subunit that is catalyzed through the activated receptor. Thus, G protein cycles between an inactive, GDP-liganded oligomeric form ("off" position), and an active, GTP-liganded monomeric state ("on" position).

A major finding of this study is the description of reduced levels of $G_s\alpha$ and $G_i\alpha$ subunit proteins in MNLs of patients with SAD winter, atypical-type depression. These findings are compatible with previous studies in patients with typical major depression.^{24,28-30} The G protein abnormalities detected in this study in depressed patients with SAD seem to be a state rather than a trait marker of SAD since (1) the same patients examined for their MNL G proteins levels in the summer, while in remission, did not show statistically significant alterations when compared with healthy control subjects; and (2) light therapy resulted in normalization of the reduced G protein immunoreactivity detected in the same patients while depressed. The results of this study are consistent with our earlier reports of MNL G protein measures as a state characteristic of mood disorders: (1) inverse picture of MNL G protein measures in bipolar mood disorder with respective increases in mania and decreases in bipolar depression^{23,24,28,30}; and (2) normalization of MNL G protein measures in patients with mood disorders with lithium,²³ antidepressants, and electroconvulsive therapy.³⁵

The mechanisms underlying the alterations in G protein levels in MNL of depressed patients with SAD and their normalization by light are still unknown. Increasing evidence indicates the existence of neural-mediated immunomodulatory mechanisms³⁶ involving the hypothalamic-pituitary-adrenal axis and the sympathetic and parasympathetic innervation of primary and secondary lymphoid organs.³⁷ These mechanisms may modulate MNL G proteins. Thus, MNL G protein alterations may reflect secondary influences of circulatory primary messengers, altered by the depressive state, or secondary influences of altered sympathetic and parasympathetic innervation of lymphoid organs induced by the depressive state.

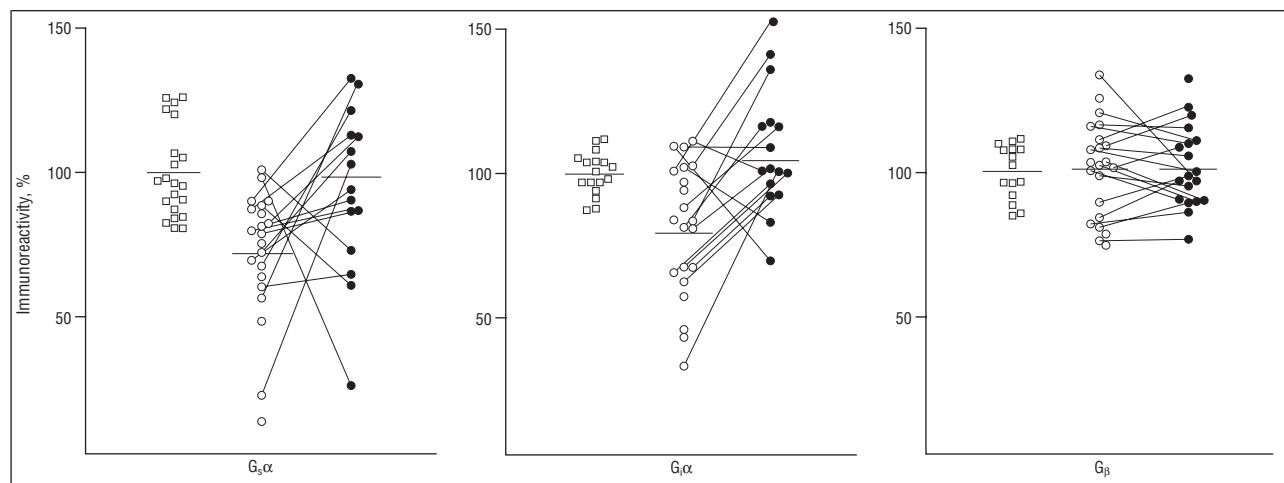

Figure 2. The effect of light therapy on the immunoreactivity of various G protein subunits in the mononuclear leukocyte levels of patients with seasonal affective disorder. The relative immunoreactivities of $G_s\alpha$ (left panel), $G_i\alpha$ (middle panel), and $G\beta$ (right panel) determined in the mononuclear leukocytes were obtained from patients with seasonal affective disorder while depressed; 21 were examined for $G_s\alpha$ and $G_i\alpha$, and 22 for $G\beta$ (open circles). After 2 weeks of light therapy, 15 were evaluated for $G_s\alpha$, 16 for $G_i\alpha$, and 19 for $G\beta$ (closed circles) as compared with normal subjects for which 21 were assessed for $G_s\alpha$, 17 for $G_i\alpha$, and 15 for $G\beta$ (open squares).

Comparison Between Clinical Improvement of Depressed Patients With SAD Treated With Light Therapy and the Normalization of G Protein Measures in Mononuclear Leukocytes of Patients*

| | No. of Patients | SIGH-SAD Score, Mean (\pm SD) | | | Clinical Remission, Percentage (\pm SD) | Biochemical Normalization, Percentage (\pm SD) | |
|------------------|-----------------|----------------------------------|------------|------------|--|---|----------------|
| | | Typical | Atypical | Total | | G _s | G _i |
| Winter depressed | 26 | 14.8 (4.6) | 11.8 (4.2) | 26.6 (6.4) | 0.0 (0) | 0.0 (0) | 0.0 (0) |
| Light treatment | | | | | | | |
| All treated | 19 | 5.8 (6.9) | 3.7 (3.3) | 9.5 (9.1) | 62.6 (31.8) | 59.9 (40.4) | 61.4 (40.6) |
| Responders | 15 | 3.2 (2.7) | 2.3 (1.9) | 5.5 (4.1) | 78.3 (15.0) | 63.6 (40.8) | 77.3 (36.5) |
| Nonresponders | 4 | 14.2 (10.1) | 8.3 (3.0) | 22.5 (9.0) | 22.6 (20.5) | 28.1 (30.1) | 20.0 (25.4) |
| Summer SAD | 22 | 2.8 (2.7) | 1.6 (1.7) | 4.1 (3.8) | 80.6 (21.7) | 72.5 (34.4) | 75.0 (40.1) |

*SAD indicates seasonal affective disorder; SIGH-SAD, Structured Interview Guide for the Hamilton Depression Rating Scale–Seasonal Affective Disorders Version.

We are aware that the involvement of G proteins in the pathophysiology of depression as implicated from the data presented here should be taken with considerable caution: findings obtained in peripheral blood cells cannot be directly extrapolated to the central nervous system. We have discussed this issue at length previously.³⁰ As we use a mixed-cell MNL preparation for our assays, the possibility remains that the alterations observed in G protein immunoreactivity reflect, at least in part, alteration in a white cell subpopulation induced by the depressive state and/or by light therapy. While G_s and G_i levels were reduced in the group of depressed patients with SAD, the G β levels remained similar to the control group. Such differential alterations would not be expected to occur owing to alterations in a white cell subpopulation.

If changes observed in MNL G protein levels in this study do reflect alterations in brain G proteins, a possible candidate may be transducin (G_t protein), which connects rhodopsin with a retinal phosphodiesterase regulating cyclic guanosine monophosphate, sodium permeability of the rod outer segment membrane, and, consequently, the electroretinogram (ERG).³⁸ It has been shown that lithium can decrease ERG amplitude and that these effects are related to inhibition of transducin,¹⁶ similar to the inhibition of G_s and G_i proteins reported previously.^{9,10} Indeed, ERG measurements have been conducted in SAD, indicating either subtle retinal changes in flash ERG³⁹ or no changes in pattern ERG⁴⁰ in depressed patients with SAD. The findings in this study of reduced MNL G protein levels in depressed patients with SAD may explain the reported subsensitivity to light in depressed patients with SAD^{41,42} by conjecturing reduced levels of transducin (G_t). Light treatment found in this study to normalize the reduced levels of MNL G proteins in depressed patients with SAD may exert its effects centrally through possible normalization of supposed G_t protein hypofunction.

Another state marker of depressed patients with SAD is their abnormal response to the somewhat selective 5-hydroxytryptamine_{2C} agonist meta-chlorophenylpiperazine.^{43,44} The reported activation and euphoria seen in depressed patients with SAD, but not in healthy controls, following administration of meta-chlorophenylpiperazine is normalized both after effective light therapy^{44,45} and in the summer.⁴³ In this regard, the meta-chlorophenylpiperazine findings resemble those in this study.

Most 5-hydroxytryptamine receptor subtypes are G protein-coupled, including 5-hydroxytryptamine_{2C}. It is possible that both light therapy and summer, which reverse the depressive symptoms of SAD, may also normalize G protein levels in both the brain and the periphery. Such putative normalization may be of relevance to the pathogenesis of symptoms.

Accepted for publication November 18, 1998.

This study was supported by a research grant from the Chief Scientist Office of the Israel Ministry of Health, Jerusalem (Drs Schreiber and Avissar), by the Yadgarov Family Foundation, Tel-Aviv, Israel (Dr Schreiber), and by the Intramural Program of the National Institute of Mental Health, National Institutes of Health, Bethesda, Md.

Corresponding author: Sofia Avissar, PhD, Department of Clinical Pharmacology, Ben Gurion University of the Negev, PO Box 653, Beer Sheva 84105, Israel (e-mail: sofia@bgumail.bgu.ac.il).

REFERENCES

- Rosenthal NE, Sack DA, Gillin JC, Lewy A J, Goodwin FK, Davenport Y, Mueller PS, Wehr TA. Seasonal affective disorder: a description of the syndrome and preliminary findings with light therapy. *Arch Gen Psychiatry*. 1984;41:72-80.
- Rosenthal NE. Diagnosis and treatment of seasonal affective disorder. *J Am Med Assoc*. 1993;270:2717-2720.
- Task Force Report of the American Psychiatric Association. *Treatment of Psychiatric Disorders*. Vol 3. Boston, Mass: APA Press; 1989;3:1890-1896.
- Rosenthal NE. The Mechanism of Action of Light in the Treatment of Seasonal Affective Disorder (SAD) in Biologic Effects of Light. Berlin, Germany: Walter de Gruyter & Co; 1996:311-324.
- Rudorfer MV, Skwerer RG, Rosenthal NE. Biogenic amines in seasonal affective disorder: effects of light therapy. *Psychiatry Res*. 1993;46:19-28.
- Joseph-Vanderpool JR, Rosenthal NE, Chrousos G, Wehr TA, Kasper S, Gold PW. Abnormal pituitary-adrenal responses to CRH in patients with seasonal affective disorder: clinical and pathophysiological implications. *J Clin Endocrinol Metab*. 1991;72:1382-1387.
- Gilman AG. G proteins: transducers of receptor-generated signals. *Annu Rev Biochem*. 1987;56:615-649.
- Hepler JR, Gilman AG. G proteins. *Trends Biochem Sci*. 1992;17:383-387.
- Avissar S, Schreiber G, Danon A, Belmaker RH. Lithium inhibits adrenergic and cholinergic increases in GTP binding in rat cortex. *Nature*. 1988;331:440-442.
- Avissar S, Schreiber G. Muscarinic receptor subclassification and G proteins: significance for lithium action in affective disorders and for the treatment of the extrapyramidal side effects of neuroleptics [Bennett Award Paper]. *Biol Psychiatry*. 1989;26:113-130.
- Avissar S, Murphy DL, Schreiber G. Magnesium reverses lithium inhibition of beta adrenergic and muscarinic receptor coupling to G proteins. *Biochem Pharmacol*. 1991;41:171-175.

12. Schreiber G, Avissar S, Aulakh CS, Murphy DL. Lithium-selective alteration of brain vs cardiac G_s protein function. *Neuropharmacology*. 1990;29:1067-1071.
13. Avissar S, Schreiber G, Aulakh CS, Murphy DL. Carbamazepine and electroconvulsive shock attenuate beta-adrenoceptor and muscarinic cholinergic coupling to G proteins in rat cortex. *Eur J Pharmacol*. 1990;100:99-103.
14. Avissar S, Schreiber G. The involvement of G proteins in the pathogenesis and treatment of affective disorders. *Biol Psychiatry*. 1992;31:435-459.
15. Avissar S, Schreiber G. Interaction of antibipolar and antidepressant treatments with receptor-coupled G proteins. *Pharmacopsychiatry*. 1992;25:44-50.
16. Meyniel G, Doly M, Gallard G. Electrophysiological demonstration of transduction inhibition by lithium. *C R Acad Sci III*. 1989;309:289-294.
17. Mork A, Geisler A. Effects of GTP on hormone-stimulated adenylate cyclase activity in cerebral cortex, striatum and hippocampus from rats treated chronically with lithium. *Biol Psychiatry*. 1989;26:279-288.
18. Newman ME, Shapira B, Lerer B. Effects of lithium and desipramine on second messenger responses in rat hippocampus: relation to G protein effects. *Neuropharmacology*. 1991;30:1297-13101.
19. Manji HK, Bitran J, Masana M, Chen G, Hsiao JK, Risby ED, Rudorfer MW, Potter WZ. Signal transduction modulation by lithium: cell culture, cerebral microdialysis and human studies. *Psychopharmacol Bull*. 1991;27:199-208
20. Song L, Jope RS. Chronic lithium treatment impairs phosphatidylinositol hydrolysis in membranes from rat brain regions. *J Neurochem*. 1992;58:2200-2206.
21. Li PP, Tam YK, Young LT, Warsh JJ. Lithium decreases G_s, G_{i-1}, G_{i-2} α subunit mRNA levels in rat cortex. *Eur J Pharmacol*. 1991;206:165-166.
22. Lesch KP, Aulakh CS, Tolliver TJ, Hill JL, Wolozin BL, Murphy DL. Differential effects of long-term lithium and carbamazepine administration on G_s,α and G_i,α protein in rat brain. *Eur J Pharmacol*. 1991;207:355-359.
23. Schreiber G, Avissar S, Danon A, Belmaker RH. Hyperfunctional G proteins in mononuclear leukocytes of patients with mania. *Biol Psychiatry*. 1991;29:273-280.
24. Avissar S, Nechamkin Y, Roitman G, Schreiber G. Differential G protein measures in mononuclear leukocytes of patients with bipolar mood disorder are state dependent. *J Affect Disord*. 1997;43:85-93.
25. Friedman E, Wang HY. Receptor-mediated activation of G proteins is increased in postmortem brains of bipolar affective disorder subjects. *J Neurochem*. 1996; 67:1145-1152.
26. Young LT, Li PP, Kish SJ, Siu KP, Warsh JJ. Post mortem cerebral cortex G_s,α subunit levels are elevated in bipolar affective disorder. *Brain Res*. 1991;553: 323-326.
27. Young LT, Li PP, Kish SJ, Siu KP, Kamble A, Hornykiewicz O, Warsh JJ. Cerebral cortex G_s protein levels and forskolin-stimulated cyclic AMP formation are increased in bipolar affective disorder. *J Neurochem*. 1993;61:890-898.
28. Avissar S, Barki-Harrington L, Nechamkin Y, Roitman G, Schreiber G. Reduced β-adrenergic receptor-coupled G_s protein function and G_s,α immunoreactivity in mononuclear leukocytes of patients with depression. *Biol Psychiatry*. 1996;39: 755-760.
29. Karege F, Bovier P, Stepanian R, Gaillard JM. Change in platelet GTP-binding protein in drug-free depressed patients. *Hum Psychopharmacol*. 1996;11:115-121.
30. Avissar S, Nechamkin Y, Roitman G, Schreiber G. Reduced G protein functions and immunoreactive levels in mononuclear leukocytes of patients with depression. *Am J Psychiatry*. 1997;154:211-217.
31. Young LT, Li PP, Kamble A, Siu KP, Warsh JJ. Mononuclear leukocyte levels of G proteins in depressed patients with bipolar disorder or major depressive disorder. *Am J Psychiatry*. 1994;151:594-596.
32. Barki-Harrington L, Nechamkin Y, Schreiber G, Avissar S. Functional and quantitative measures of receptor coupled G proteins in human mononuclear leukocytes: no change with age. *Exp Gerontol*. 1996;31:351-363.
33. Williams JBW, Link MJ, Rosenthal NE, Terman M. Structured Interview Guide for the Hamilton Depression Scale-Seasonal Affective Disorder Version. New York, NY: New York State Psychiatric Institute; 1988.
34. Terman JS, Terman M, Schlager D, Raftery B, Rosofsky AB, Link MJ, Gallin PF, Quitkin FM. Efficacy of brief, intense light exposure for treatment of winter depression. *Psychopharmacol Bull*. 1990;26:3-11.
35. Avissar S, Nechamkin Y, Roitman G, Schreiber G. Normalization dynamics by electroconvulsive treatment of reduced G protein levels and functions in mononuclear leukocytes of patients with major depression. *Am J Psychiatry*. 1998; 155:666-671.
36. Roszman TL, Brooks WH. Neural modulation of immune function. *J Neuroimmunol*. 1985;10:59-69.
37. Livnat S, Felten SY, Carlson SL, Bellinger DL, Felten DL. Involvement of peripheral and central catecholamine systems in neural immune interactions. *J Neuroimmunol*. 1985;10:5-30.
38. Fung BKK, Hurley JB, Stryer L. Flow of information in the light-triggered cyclic nucleotide cascade of vision. *Proc Natl Acad Sci USA*. 1981;78:152-156.
39. Lam RW, Beattie CW, Buchanan A, Mador JA. Electroretinography in seasonal affective disorder. *Psychiatry Res*. 1992;43:55-63.
40. Oren DA, Moul DE, Schwartz PJ, Alexander JR, Yamada EM, Rosenthal NE. An investigation of ophthalmic function in winter seasonal affective disorder. *Depression*. 1993;1:29-37.
41. Lam RW, Beattie CW, Buchanan A, Remick RA, Zis AP. Low electrooculographic ratios in patients with seasonal affective disorder. *Am J Psychiatry*. 1991;148: 1526-1529.
42. Ozaki N, Rosenthal NE, Myers F, Schwartz PJ, Oren DA. Effects of season on electro-oculographic ratio in winter seasonal affective disorder. *Psychiatry Res*. 1995;59:151-155.
43. Joseph-Vanderpool JR, Jacobsen FM, Murphy DL, Hill JL, Rosenthal NE. Seasonal variation in behavioral responses to m-CPP in patients with seasonal affective disorder and controls. *Biol Psychiatry*. 1993;33:496-504.
44. Schwartz PJ, Murphy DL, Garcia-Borreguero D, Oren DA, Moul DE, Ozaki N, Snelbaker AJ, Wehr TA, Rosenthal NE. Effects of m-CPP infusions in patients with seasonal affective disorder and healthy controls: diurnal responses and nocturnal regulatory mechanisms. *Arch Gen Psychiatry*. In press.
45. Jacobsen FM, Mueller EA, Rosenthal NE, Rogers S, Hill JL, Murphy DL. Behavioral responses to intravenous meta-chlorophenylpiperazine in patients with seasonal affective disorder and control subjects before and after phototherapy. *Psychiatry Res*. 1994;52:181-197.