

Developmental Twin Study of Attention Problems

High Heritabilities Throughout Development

Zheng Chang, MSc; Paul Lichtenstein, PhD; Philip J. Asherson, PhD; Henrik Larsson, PhD

Context: The genetic and environmental link between attention-deficit/hyperactivity disorder in childhood and the adult manifestation of the disorder is poorly understood because of a lack of longitudinal studies with cross-informant data.

Objective: To explore the relative contribution of genetic and environmental influences on symptoms of attention problems from childhood to early adulthood.

Design: Analysis was conducted using longitudinal structural equation modeling with multiple informants.

Setting: The Swedish Twin Study of Child and Adolescent Development.

Participants: One thousand four hundred eighty twin pairs were prospectively followed up from childhood to young adulthood.

Main Outcome Measures: Symptoms were obtained using parent and self-ratings of the Attention Problems Scale at ages 8 to 9, 13 to 14, 16 to 17, and 19 to 20 years.

Results: The best-fitting model revealed high heritability of attention problems as indexed by parent and self-ratings from childhood to early adulthood ($h^2=0.77-0.82$). Genetic effects operating at age 8 to 9 years continued, explaining 41%, 34%, and 24% of the total variance at ages 13 to 14, 16 to 17, and 19 to 20 years. Moreover, new sets of genetic risk factors emerged at ages 13 to 14, 16 to 17, and 19 to 20 years.

Conclusions: The shared view of self- and informant-rated attention problems is highly heritable in childhood, adolescence, and early adulthood, suggesting that the previous reports of low heritability for attention-deficit/hyperactivity disorder in adults are best explained by rater effects. Both genetic stability and genetic innovation were present throughout this developmental stage, suggesting that attention problems are a developmentally complex phenotype characterized by both continuity and change across the life span.

JAMA Psychiatry. 2013;70(3):311-318.

Published online January 2, 2013.

doi:10.1001/jamapsychiatry.2013.287

Author Affiliations: Department of Medical Epidemiology and Biostatistics, Karolinska Institutet (Mr Chang and Drs Lichtenstein and Larsson), and Karolinska Institutet Center of Neurodevelopmental Disorders (Dr Larsson), Stockholm, Sweden; and Institute of Psychiatry, King's College London, London, England (Dr Asherson).

ATENTION-DEFICIT/HYPERactivity disorder (ADHD) is one of the most common developmental disorders in child and adolescent psychiatry, with an estimated worldwide prevalence rate around 5%.¹ Follow-up studies of children with ADHD into adolescence and early adulthood show a substantial degree of persistence over time,^{2,3} with around 65% of children with ADHD continuing to meet full or partial remission criteria by the age of 25 years.⁴ Despite the increased level of interest in ADHD in adults,^{5,6} to our knowledge, no previous studies have investigated the impact of genetic and environmental risk factors on ADHD from childhood to young adulthood, using a developmental, genetically sensitive design with multi-informant data.

Twin studies based on parent and teacher ratings yield high heritability estimates for ADHD symptoms in childhood and adolescence, usually in the range of 70% to 80%.⁷ In contrast, the few twin studies that have investigated ADHD in adults, all based on self-ratings, reveal lower heritability estimates between 30% and 40%.⁸⁻¹⁰ However, because there are no published informant or cross-informant data on adult twins, it is still unclear whether these previous studies indicate a true drop in the heritability of ADHD in adults compared with children or whether this relates to the use of self-ratings in contrast to informant data.¹¹ Results from a recent meta-analysis, suggesting that the magnitude of the nonshared environmental component of ADHD increases with age,¹² predict the former. In contrast, findings from clinical-based fam-

ily studies, showing a high familial loading on ADHD in adults,¹³⁻¹⁶ predict the latter.

Most of the previous twin studies have used cross-sectional data to estimate heritabilities at different ages and are therefore unable to distinguish stable genetic risk factors that influence the disorder over time from genetic factors that emerge during development. The few available longitudinal twin results¹⁷⁻²⁰ suggest that some of the genes influencing ADHD at an early age continue to operate in adolescence, providing evidence for stable genetic influences on ADHD. The genetic overlap across different ages was far from complete in these studies, with evidence that new sources of genetic effects emerge at different developmental stages and that the impact of earlier genetic risk factors declines over time. Unfortunately, none of these studies followed up the twins from childhood into adulthood, so although strong familial influences have been identified for ADHD that persists into adulthood,¹³⁻¹⁶ little is known about the dynamic nature of the genetic risk factors for ADHD during the transition from childhood and adolescence to adulthood. Knowledge about the developmental structure of genetic risk factors for ADHD from childhood to adulthood would help to clarify the nature of the etiological links between ADHD in children and adults.

In this study, we explored the impact of genetic and environmental risk factors for the ADHD-sensitive²¹⁻²³ Attention Problems (AP) Scale of the Achenbach System of Empirically Based Assessment.²⁴⁻²⁶ The AP Scale includes symptoms of inattention, hyperactivity, and impulsivity and therefore covers the 3 main symptom domains of ADHD. We applied a longitudinal design, using multi-informant data that combined parent and self-ratings to generate an index of an unobserved latent factor that reflects the shared view across raters. The use of both parent- and self-rated data allowed us to explore whether the previous reports of low heritability for ADHD (and the AP Scale) in adults are best explained by rater effects or developmental effects. The developmental design was used to examine, for the first time to our knowledge, the continuity and change in genetic and environmental risk factors from childhood into early adulthood. The main focus of the longitudinal analyses was to discriminate between “developmentally stable” genetic risk factors (ie, predicting that the genetic liability originates solely from a single set of genes that influence ADHD symptoms throughout child to adult development) and “developmentally dynamic” genetic risk factors (ie, predicting that new genetic effects emerge over development and also that the impact of earlier genetic risk factors declines over time).

METHODS

SAMPLE

This study was based on data from the Twin Study of Child and Adolescent Development.²⁷ The target sample consisted of all the 1480 twin pairs born in Sweden between May 1985 and December 1986 who were alive and residing in Sweden in 1994. They were assessed 4 times via mailed questionnaires: at age 8 to 9 years questionnaires mailed to parents (n=1109 or 75%

response of those eligible), age 13 to 14 years questionnaires mailed to parents (n=1063, 73%) and children (n=2263, 78%), and age 16 to 17 years questionnaires mailed to parents (n=1067, 74%) and children (n=2369, 82%), with a majority of the parent-reported information supplied by mothers rather than by fathers (75%-90%). At age 19 to 20 years, both parents were approached separately, with responses from at least 1 of the parents for 1158 twins and self-report from 1705 twins (59%). Some evidence of selective attrition over time was present; attrition rates were higher in individuals with elevated levels of symptoms on the AP Scale, and attrition rates at age 19 to 20 years were higher in boys. Zygosity was assessed by DNA testing. The twins' DNA was extracted from saliva samples using an Ora-Gen DNA self-collection kit (DNA Genotek Inc). For twins without a DNA sample, zygosity was determined based on an algorithm derived from discriminant analyses of twins' and parents' responses to validated zygosity questionnaires.^{27,28} In cases of any contradictions between the assignments (n=100, 3.4%), the zygosity was set to unknown, and the twins were excluded from the analyses. Each wave of data collection was approved separately by the ethics committee of Karolinska Institutet, Stockholm, Sweden.

MEASURES

Parent ratings consisted of items from the AP Scale of the Child Behavior Checklist (CBCL)²⁴ when the twins were aged 8 to 17 years and from the Adult Behavior Checklist (ABCL)²⁶ at age 19 to 20 years. Self-ratings consisted of items from the same AP Scale from the Youth Self-Report form (YSR)²⁵ when the twins were aged 13 to 14 and 16 to 17 years and from the Adult Self-Report form (ASR)²⁶ at age 19 to 20 years. The CBCL, YSR, ABCL, and ASR are standardized questionnaires for parents and children to rate the children's frequency and intensity of behavioral and emotional problems exhibited in the past 6 months. The AP Scale assesses problems related both to inattention and hyperactivity-impulsivity (eTable 1, <http://www.jamapsych.com>) and has been found to predict ADHD status.²¹⁻²³ We therefore consider the AP Scale to be a measure of ADHD symptoms. The psychometric properties of these scales have been examined in both population-based and clinical samples, presenting good reliability, as well as convergent and discriminative validity.^{24-26,29} All items were scored on a 3-point scale (0=not true; 1=sometimes true; and 2=often true). The YSR is based on self-ratings but consists of the same items as those in the CBCL. The ABCL and ASR consist of similar or developmentally appropriate counterparts of items used in CBCL and YSR. Because item performance could vary by rater, sex, or age, we created factor scores of AP separately for each combination of these factors (eg, parent ratings of boys at age 8-9 years).³⁰ Factor loadings were calculated for each item in the program Mplus,³¹ using a robust weighted least squares estimator.

DATA ANALYSIS

In multivariate twin models, the variance of each phenotype and covariance between phenotypes are decomposed into additive genetic (A), dominant genetic (D) or shared environmental (C), and unique environmental (E) influences. We used a model, illustrated in **Figure 1**, designed to estimate the proportion of variance in AP explained by A, C or D, and E over the 4 times of measurement.

Both parent ratings and self-ratings are used as indicators for the latent factors of AP (AP₁-AP₄). The paths λ_p and λ_s reflect the degree to which parent ratings and self-ratings of AP index the latent factors of AP. The genetic and environmental influences on AP₁ to AP₄ are modeled as Cholesky decompo-

sition. The factor structure depicted by latent factors F_1 through F_4 is implemented for the 3 sources of variance A, C or D, and E. This developmentally informative approach divides genetic risk of AP_1 to AP_4 into 4 factors (F_1 - F_4). The first factor, F_1 , contributes to variation at age 8 to 9 years (time 1) and impacts times 2, 3, and 4 as well. The second factor, F_2 , contributes to variation at age 13 to 14 years (time 2) and additionally impacts times 3 and 4. The third factor, F_3 , starts at age 16 to 17 years (time 3) and also impacts time 4, and the last factor, F_4 , impacts only age 19 to 20 years (time 4). The model also contains 2 rater-specific common factors for parent ratings (F_p) and self-ratings (F_s). These factors allow the model to estimate genetic and environmental influences on ratings that are unique to the parents or children. The remaining part of the phenotypic variance is modeled as rater-specific error effects (R_{p1} - R_{s4}). This model has previously been described in detail in a developmental twin study of fears.³²

We examined qualitative and quantitative sex effects on AP. Qualitative sex effects, which arise when genetic factors influencing a trait are not identical in males and females, are measured by the genetic correlation r_g , which can vary from zero (ie, entirely distinct sets of genes in the 2 sexes) to unity (ie, identical genetic factors impacting males and females). Quantitative sex effects arise when the same genetic factors impact males and females but to different degrees. This was implemented by allowing all path coefficients to be estimated separately by sex.

Analyses were performed using the Mx software package.³³ Factor scores for AP were approximately normally distributed (skewness range, 0.27 to 1.15, kurtosis range, -0.56 to 0.52) and were treated as continuous traits. Traditionally, the likelihood ratio test has been used to compare the fit of nested models. More recently, the Bayesian information criterion (BIC), which measures model fit relative to parsimony, has been shown to perform well with regard to its ability to discriminate between multivariate behavioral genetic models³⁴ and is widely used in studies with complex models.^{32,35,36} In this study, we used BIC to evaluate the fit of models, and the lower the BIC value, the better the balance of explanatory power and parsimony. Estimations of path coefficients and their confidence intervals were obtained with maximum-likelihood model fitting using raw data.

RESULTS

Table 1 presents the correlations matrix for AP across raters and across time. In line with prior cross-informant data on child and adolescent psychopathology,³⁷ within-time correlations (ie, between parent ratings and self-ratings) were similar across the 3 times, ranging from 0.33 to 0.39. Cross-time within-rater correlations ranged from 0.36 to 0.60, whereas cross-time cross-rater correlations ranged from 0.07 to 0.33. Both types of cross-time correlations declined as the interval increased.

Twin correlations for parent and self-rated AP, within and across time for the 5 zygosity groups (male monozygotic, male dizygotic, female monozygotic, female dizygotic, and male-female dizygotic), are reported in eTable 2. Consistent with prior research,²⁰ within-time monozygotic correlations were approximately twice as large as the corresponding dizygotic correlations, indicating genetic influences on AP at each time. Monozygotic cross-time cross-twin correlations were higher than those of dizygotic twins, indicating genetic influences on the stability of AP over time. The cross-informant/cross-twin correlations and the cross-time/cross-informant/cross-twin correlations also indi-

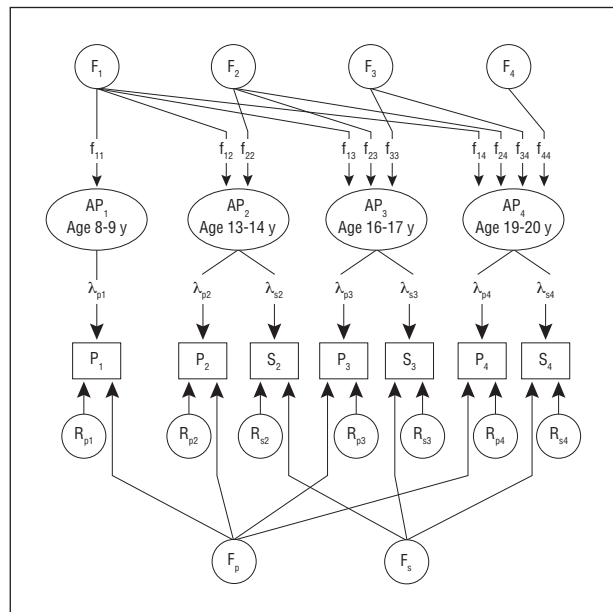

Figure 1. The model used in the current analyses presented for 1 source of liability, such as additive genetic effects. The model contains 4 latent factors of AP_1 to AP_4 reflecting the “true” level of attention problems (AP) for each point. These latent variables are indexed by ratings of AP by parental report (P) and self-report (S). The degree to which the parent- and self-reported ratings of AP index these latent factors is reflected by the paths λ_p and λ_s . The genetic and environmental influences on AP_1 to AP_4 are modeled as a Cholesky decomposition. See the “Data Analysis” subsection and “Results” section for further details (adapted from Kendler et al³²).

cated evidence of genetic influences.

Model fitting (**Table 2**) began with a full model allowing for both qualitative and quantitative sex differences for the estimation of A, C, and E on latent factors (model 1) and an alternative ADE model (model 2). The ADE model fitted the data better as indexed by a lower BIC value. The results from model 2 showed similar parameter estimates for males and females (data not shown). We then attempted to simplify this model by dropping the qualitative and quantitative sex effects, and the BIC favored the more parsimonious model (model 3, $\Delta BIC = -97.8$). We continued to test whether the D component could be dropped from the model (model 4). Results showed that an AE model ($\Delta BIC = -19.0$) without a sex effect provided the best fit with a balance of explanatory power and parsimony. Parameter estimates from the ADE model (model 3) are also presented in eTable 3. Dominant genetic effects accounted for part of the broad-sense heritability (ie, D explained 29%-60%) at each age, but the general pattern of results was similar to the results from the best-fitting model.

Standardized parameter estimates for the genetic and environmental contribution (as illustrated in the upper part of Figure 1), along with 95% confidence intervals, are shown in **Table 3**, and the relative contributions of genetic and nonshared environmental factors are also illustrated in **Figure 2**. The results showed that genetic factors had a strong influence on AP, as indexed by the shared view of parent and self-ratings, across the 4 times (AP_1 - AP_4). The heritability (h^2) estimates for AP_1 to AP_4 were 77%, 82%, 82%, and 78%, respectively, and thus higher than those based on parent ratings (0.59-0.70) or

Table 1. Pearson Correlations for Attention Problems Across Raters and Time

Age, y/ Rater	Age 8-9 y		Age 13-14 y		Age 16-17 y		Age 19-20 y	
	Parent	Parent	Self	Parent	Self	Parent	Self	
8-9/Parent		0.54	0.25	0.43	0.19	0.36	0.07	
13-14/Parent			0.39	0.60	0.33	0.45	0.19	
13-14/Self				0.31	0.53	0.28	0.36	
16-17/Parent					0.38	0.48	0.18	
16-17/Self						0.27	0.42	
19-20/Parent							0.33	
19-20/Self								

Table 2. Model Fitting Results for Attention Problems

Model	Compared With Model	Description	BIC	ΔBIC	-2ll	Δχ ² (Δdf)	P Value
1		Full ACE model	-43 172.9		9463.1		
2		Full ADE model	-43 185.4		9438.1		
3	2	ADE, no sex effect	-43 283.2	-97.8	9486.7	48.6 (34)	.05
4 ^a	3	AE, no sex effect	-43 302.2	-19.0	9520.4	33.7 (10)	<.01

Abbreviations: ACE, additive genetic, shared environmental, and unique environmental; ADE, additive genetic, dominant genetic, and unique environmental; AE, additive genetic and unique environmental; BIC, Bayesian information criterion; ll, log likelihood.

^aBest-fitting model.

Table 3. Parameter Estimates With 95% CIs for the Best-Fitting Model (AP₁ to AP₄)

Factor (Age, y)	Genetic Factor, Estimate (95% CI)				Unique Environmental Factor, Estimate (95% CI)					
	Total h ² , %	A1	A2	A3	A4	Total e ² , %	E1	E2	E3	E4
AP ₁ (8-9)	77	0.88 (0.76 to 0.99)				23	0.48 (0.04 to 0.65)			
AP ₂ (13-14)	82	0.64 (0.56 to 0.73)	0.64 (0.53 to 0.71)			18	0.17 (-0.06 to 0.48)	0.39 (-0.49 to 0.49)		
AP ₃ (16-17)	82	0.59 (0.50 to 0.67)	0.47 (0.36 to 0.57)	0.51 (0.42 to 0.57)		18	0.09 (-0.09 to 0.48)	0.39 (-0.48 to 0.48)	0.12 (-0.28 to 0.28)	
AP ₄ (19-20)	78	0.49 (0.38 to 0.60)	0.39 (0.24 to 0.53)	0.29 (0.14 to 0.46)	0.55 (0.37 to 0.66)	22	-0.12 (-0.49 to 0.39)	0.25 (0.03 to 0.58)	-0.37 (-0.55 to 0.55)	0.01 (-0.53 to 0.53)

Abbreviations: AP, attention problems; e², the proportion of variance in AP explained by unique environmental factors; h², the proportion of variance in AP explained by genetic factors.

self-ratings (0.45-0.53) alone (eTable 4). Unique environmental factors (e²) accounted for the remaining part of the variance (ie, 18%-23%). When considered separately, heritability estimates from the parent-rated data were approximately 20% higher than those from self-rated data at ages 16 to 17 and 19 to 20 years, with no evidence for a significant decline in heritability with increasing age.

Using the combined parent- and self-rated index of AP, the first genetic factor (A1) explained 77% (0.88²) of the total variance of AP₁ by age 8 to 9 years and continued to impact AP but declined in influence with time, that is, 41% (0.64²) of the variance at age 13 to 14 years, 34% (0.59²) at age 16 to 17 years, and 24% (0.49²) at age 19 to 20 years. In addition to the temporally stable genetic factor from childhood (age 8-9 years), new sources of genetic influence on AP emerged at subsequent ages: the second genetic factor (A2) explained 41% (0.64²) of the variance in AP₂ by age 13 to 14 years; A3 explained 25% (0.51²) of the variance in AP₃ by age 16 to 17 years;

and A4 explained 30% (0.55²) of the variance in AP₄ by age 19 to 20 years. These new sources of genetic factors (A2 and A3) also continued to impact later times. In contrast to the genetic factors, the first unique environmental factor (E1) at age 8 to 9 years attenuated sharply over time, while the impact of E2 continued over time, suggesting some environmental experiences around puberty have an enduring impact over time.

In addition to the effect of the latent AP factors (AP₁-AP₄) on AP, we also examined to what extent the observed parent (P₁-P₄) and self-ratings (S₂-S₄) were influenced by the rater-specific effects. The variances of observed parent (P₁-P₄ in Figure 1) and self-ratings (S₂-S₄) were decomposed into cross-informant effect (λ_{sp}), rater-specific effect (F_{sp}), and rater-specific error (R_{sp}). Standardized parameters from the best-fitting model are presented in eTable 5.

At the 3 times for which both parent ratings and self-ratings were available, the λ_p paths were higher than the λ_s paths. That is, the cross-informant factor AP₁ to AP₄

contributed more to parent-rated AP than to self-rated AP (**Figure 3**), suggesting that parent ratings were a better index of the shared view of AP than self-ratings. In contrast to the rater effect on the latent common factors (AP_1 - AP_4), the rater-specific common factors (F_p and F_s) were stronger for self-ratings than for parent ratings. At all times, the common rater-specific factor of parent ratings (F_p ; $F_p = a^2 + c^2 + e^2$) constituted a small proportion of the total variance (6%-24%) in parent-rated AP, whereas the common rater-specific factor of self-ratings (F_s) contributed to a nontrivial proportion (26%-70%) of the variance in self-rated AP. Also, self-ratings included a large proportion of rater-specific error effects (R_s), explaining 8% to 60% of the variance. In contrast, the rater-specific error effects for the parent ratings were relatively small in magnitude (0.1%-20%).

COMMENT

The present study found that the shared view of self- and informant-rated ADHD symptoms, measured using the AP Scale, was highly heritable in childhood, adolescence, and early adulthood. This suggests that heritability estimates for ADHD are stable during the transition from childhood into young adulthood and that the previous reports of low heritability for ADHD symptoms in adults are best explained by rater effects giving rise to measurement error, rather than developmental effects. This can also be seen in the univariate heritability estimates, which showed greater heritability for the parent-rated measures compared with the self-rated measures, particularly in the late adolescent and young adult age groups.

Even though one-fourth of the heritability in adulthood was shared with childhood manifestations of AP, indicating the presence of stable genetic risk factors that influence ADHD symptoms over time, we also found evidence of new genetic factors that emerged during the transition from child through adolescent to young adult development, suggesting that ADHD is a developmentally complex phenotype characterized by both continuity and change of the genetic influences across the life span.^{3,4}

To our knowledge, this study is the first to show that multi-informant ratings of ADHD-related phenotypes in adults are highly heritable. Our heritability estimate of AP in adults is in accordance with previous twin studies using parent or teacher ratings of children and adolescents^{17,20} but substantially higher than what has been reported in twin studies using self-ratings of AP or ADHD in childhood^{38,39} and adulthood.^{9,10} One possible explanation is the use of multiple informants. Usually in the basic twin model, the nonshared environmental (E) component captures variance due to both unique environmental influences and measurement error. The multi-informant design, used in the current study, enabled us to distinguish true unique environmental effects from variance explained by rater-specific measurement error. Because the high heritability presented in the current study was corrected for the unreliability in previous reports by the use of multiple informants, our results suggest that recent findings of lower heritability for self-rated ADHD in adults do not reflect a true drop in the magnitude of

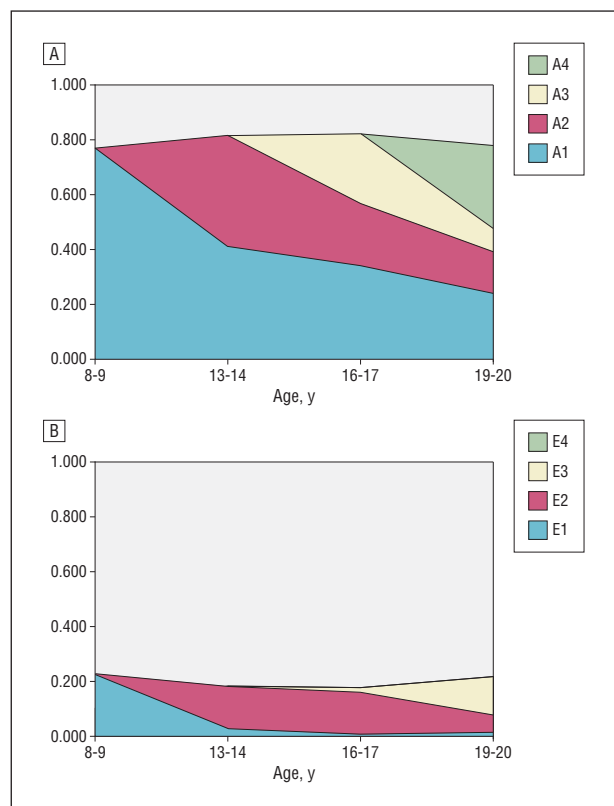

Figure 2. The proportion of the total variance in latent estimation of attention problems accounted for genetic factors (A) and unique environmental factors (B) through development.

the genetic influences on ADHD in adults, but rather an increased contribution of measurement error, reflecting accuracy of the measures. Similar results have been observed in studies of parent-offspring ADHD showing greater parent-offspring associations with informant report or cognitive performance data than self-ratings.⁴⁰⁻⁴² Of particular interest, our finding of a high cross-informant heritability estimate for AP in early adulthood is consistent with findings from clinical-based family studies showing a high familial loading on ADHD in adults.^{13,14,16} Taken together, our results indicate that in twin studies of ADHD symptoms in adults, the use of multiple informants as compared with self-ratings only produces heritability estimates more in line with the results from family studies of clinically referred adult patients and previous estimates of heritability in children and adolescents.

The developmental design of this study allowed us not only to report the cross-sectional heritability estimates across different ages, but also to distinguish between stable and changing genetic risk factors during development. We found evidence of both stable and dynamic genetic influences over the course of the development from childhood into early adulthood, which extends previous studies of childhood and adolescent ADHD symptoms.^{17,18,20} The finding that the first genetic factor, operating in childhood, explained a moderate amount (24%) of variation in early adulthood provides strong support for genetic stability. However, in line with the “developmentally dynamic” hypothesis, new sources of genetic effects on AP

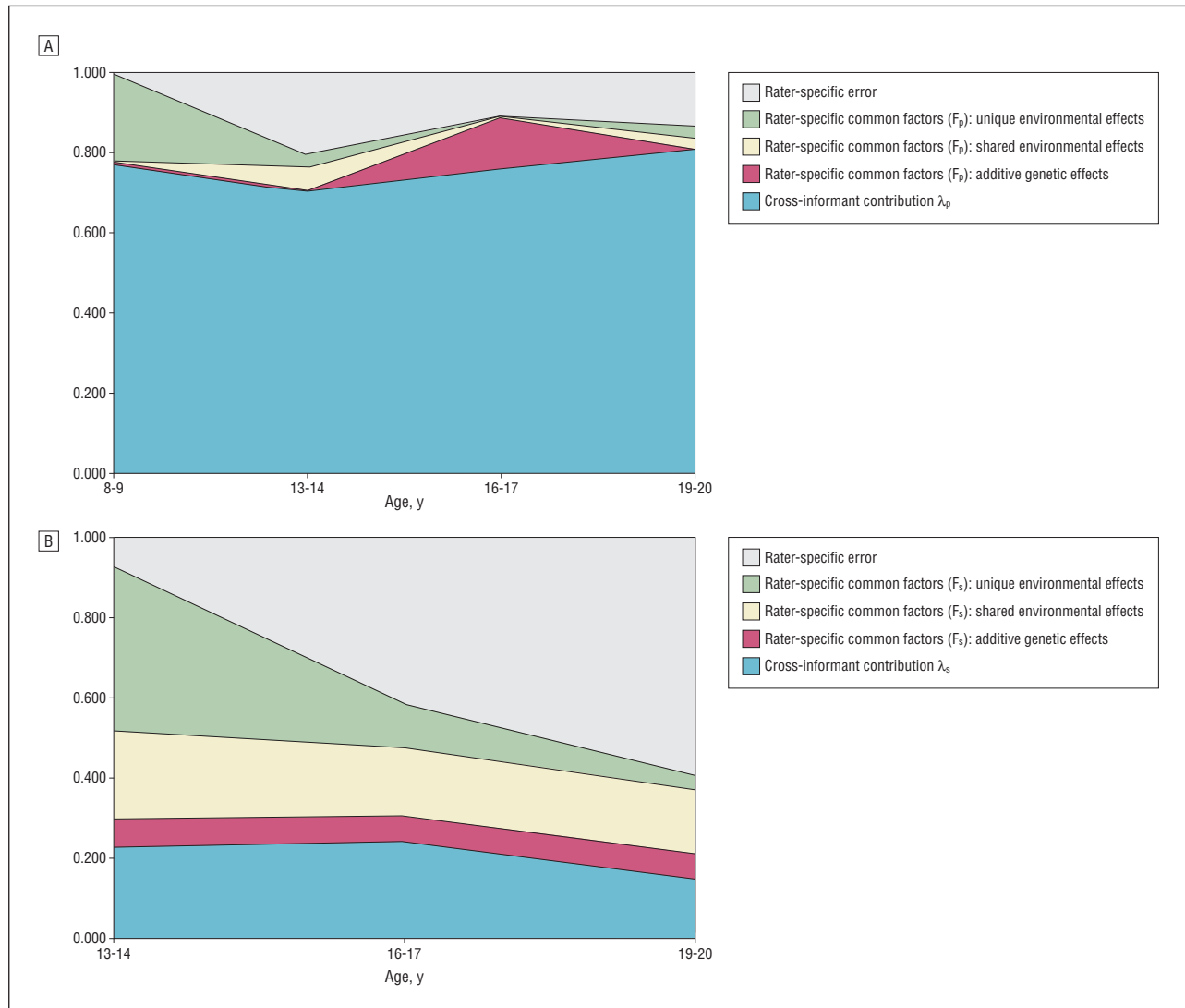

Figure 3. Variance components that contribute to the observed ratings of attention problems for parental report (A) and self-report (B).

emerged over the development (ie, genetic innovation), and the genetic factors that act in childhood declined in influence with age (ie, genetic attenuation). Consistent with the available literature,⁴³⁻⁴⁶ our results suggest that molecular genetic studies of ADHD symptoms in adults will identify genes that are shared with childhood ADHD and represent developmentally stable genetic influences but also those that are newly arising, perhaps involving processes that lead to persistence or remission of the disorder as children with ADHD grow older. Our findings regarding the stable and dynamic nature of the genetic risks may also link to the neurodevelopmental model of Halperin and colleagues,^{47,48} which postulates that ADHD is associated with early-appearing and enduring subcortical dysfunctions, while persistence over the course of development is associated with prefrontally mediated executive control functions. These 2 factors may mediate the observed genetic stability and innovation, with innovative genetic influences being related to cortical maturation and the degree of cognitive control. Future developmental twin studies with neuropsychological data are needed to explore further the extent

to which stable and/or dynamic genetic influences are mediated by specific brain functions.

Studies on developmental behavioral problems from childhood to adulthood face the problem that parent ratings are often considered more accurate than self-ratings in childhood⁴⁹ but may underestimate behavioral problems compared with self-ratings in adulthood (eg, conduct problem).⁵⁰ Our model showed that parent ratings contributed more strongly to the latent AP factors than self-ratings and included less measurement error. Therefore, based on our results and prior research,^{51,52} we recommend that future follow-up studies of ADHD into adulthood should include parent ratings, if possible, in addition to self-ratings. Data from both types of informants are particularly important because validation studies of the assessment of ADHD in adults are still inconclusive.⁵³ In addition, we cannot rule out that self-reports may become more accurate in older adult samples, even though this seems unlikely because studies of self-rated ADHD symptoms in adults have shown low heritability estimates and substantial nonshared environmental influences (including measurement error).⁹ Moreover, our results clearly

showed that a cross-informant measure of ADHD identifies a highly heritable phenotype and that different genetic risk factors account for the heritability at different stages of development. We therefore propose that longitudinal population-based twin samples using a multi-informant quantitative trait loci approach represent a powerful strategy, as an alternative to the more frequently used clinical case-control design, for identifying replicable DNA variants associations with ADHD.

The results in this study should be considered in the context of its limitations. First, the participation rate at wave 4 was lower than at waves 1 to 3, most likely because many of the twins moved away from their parents so they were less likely to receive the questionnaires. Attrition was also associated with sex (ie, higher in boys) and elevated levels of childhood AP. It is, thus, possible that the variation of AP at the extreme is truncated and the results may therefore not be generalizable to cases with the most extreme AP scores. However, it is unlikely that attrition biased the genetic and environmental parameter estimates, because the intraclass correlations at baseline (age 8-9 years) were similar among longitudinal responders and nonresponders. In addition, the sample is representative of the Swedish population with regard to educational level and employment status.²⁷ Second, although the parents were asked to rate their children's behavioral problems exhibited in the past 6 months, it is possible that ratings in early adulthood (age 19-20 years) may be influenced by the offspring's behavior at earlier ages. However, this is unlikely in the current sample since the cross-time correlation for parent rating between age 16 to 17 years and age 19 to 20 years was not higher than the correlation between age 13 to 14 years and age 16 to 17 years. Third, our measures (ie, the AP scales on the CBCL and YSR) were not specifically designed to identify the 2 symptom domains of ADHD (inattention vs hyperactivity-impulsivity), which may have constrained possibilities to detect subtype-specific dominant genetic effects.¹² Also, some of the items in the AP Scale are not ADHD specific (eg, acts young, daydreams), and the AP Scale of ABCL/ASR includes fewer hyperactive-impulsive items than those of CBCL/YSR. Thus, our finding of new emerging factors may partly reflect differences across time in the assessment of AP. However, sensitivity analyses were first conducted using a DSM-oriented ADHD scale from the empirically based assessment (CBCL, YSR, ABCL and ASR),^{54,55} which included more hyperactive-impulsive items. Similar results were observed, including high heritability estimates from childhood to early adulthood ($h^2 = 0.71-0.84$), genetic stability, and innovation. Furthermore, we refitted the model, but now using a reduced number of AP items that were available at all times and for all scales, and similar results were observed. Fourth, some of the results might be biased because we had only parent ratings at age 8 to 9 years. To examine this, we first refitted our model, but now only using data from times 2, 3, and 4, for which both informants were available. In a second step, we fitted a basic Cholesky model directly on our 7 observed measurements. The results from these 2 models showed a similar pattern as what we have described in this article. Fifth, the current sample is a Swedish birth cohort, and the extent to which the results could extrapolate to other populations has yet to be examined.

In conclusion, we have demonstrated, using multi-informant assessments, that ADHD symptoms, as measured using the AP Scale and capturing the shared view of parents and self-ratings, are highly heritable from childhood into early adulthood. We also show that the developmental structure of genetic risk factors for AP is best explained by both stable and dynamic processes. The stable component of the genetic risk suggests, consistent with prior studies,^{17,18,20} that persistent ADHD and its pediatric form are genetically linked.

Submitted for Publication: March 26, 2012; final revision received May 21, 2012; accepted June 26, 2012.

Published Online: January 2, 2013. doi:10.1001/jamapsychiatry.2013.287

Correspondence: Zheng Chang, MSc, Department of Medical Epidemiology and Biostatistics, Karolinska Institutet, PO Box 281, SE-171 77 Stockholm, Sweden (zheng.chang@ki.se).

Conflict of Interest Disclosures: Dr Asherson has received funding for educational and research activities from Janssen-Cilag and Shire and has received consultancy and speaker fees from Eli Lilly and Company, Flynn Pharma, Janssen-Cilag, and Shire that have been used for educational and research activities.

Funding/Support: This research was supported by grants from the Swedish Council for Working Life and Social Research and the Swedish Research Council (grants 2010-3184 and 2011-2492).

Previous Presentation: The Abstract of this article was presented at the 2011 Behavior Genetics Association 41st Annual Meeting; June 7, 2011; Newport, Rhode Island.

Online-Only Material: The eTables are available at <http://www.jamapsych.com>.

REFERENCES

1. Polanczyk G, de Lima MS, Horta BL, Biederman J, Rohde LA. The worldwide prevalence of ADHD: a systematic review and meta-regression analysis. *Am J Psychiatry*. 2007;164(6):942-948.
2. Biederman J, Petty CR, Clarke A, Lomedico A, Faraone SV. Predictors of persistent ADHD: an 11-year follow-up study. *J Psychiatr Res*. 2011;45(2):150-155.
3. Biederman J, Petty CR, Evans M, Small J, Faraone SV. How persistent is ADHD? a controlled 10-year follow-up study of boys with ADHD. *Psychiatry Res*. 2010;177(3):299-304.
4. Faraone SV, Biederman J, Mick E. The age-dependent decline of attention deficit hyperactivity disorder: a meta-analysis of follow-up studies. *Psychol Med*. 2006;36(2):159-165.
5. Wilens TE, Faraone SV, Biederman J. Attention-deficit/hyperactivity disorder in adults. *JAMA*. 2004;292(5):619-623.
6. Barkley RA. Global issues related to the impact of untreated attention-deficit/hyperactivity disorder from childhood to young adulthood. *Postgrad Med*. 2008;120(3):48-59.
7. Faraone SV, Perlis RH, Doyle AE, Smoller JW, Goralnick JJ, Holmgren MA, Sklar P. Molecular genetics of attention-deficit/hyperactivity disorder. *Biol Psychiatry*. 2005;57(11):1313-1323.
8. Reiersen AM, Constantino JN, Grimmer M, Martin NG, Todd RD. Evidence for shared genetic influences on self-reported ADHD and autistic symptoms in young adult Australian twins. *Twin Res Hum Genet*. 2008;11(6):579-585.
9. Boomsma DI, Saviouk V, Hottenga JJ, Distel MA, de Moor MH, Vink JM, Geels LM, van Beek JH, Bartels M, de Geus EJ, Willemsen G. Genetic epidemiology of attention deficit hyperactivity disorder (ADHD index) in adults. *PLoS One*. 2010;5(5):e10621.
10. van den Berg SM, Willemsen G, de Geus EJ, Boomsma DI. Genetic etiology of stability of attention problems in young adulthood. *Am J Med Genet B Neuropsychiatr Genet*. 2006;141B(1):55-60.
11. Rakofsky JJ, Ressler KJ, Dunlop BW. BDNF function as a potential mediator of

- bipolar disorder and post-traumatic stress disorder comorbidity. *Mol Psychiatry*. 2012;17(1):22-35.
12. Nikolas MA, Burt SA. Genetic and environmental influences on ADHD symptom dimensions of inattention and hyperactivity: a meta-analysis. *J Abnorm Psychol*. 2010;119(1):1-17.
 13. Biederman J, Faraone S, Milberger S, Curtis S, Chen L, Marrs A, Ouellette C, Moore P, Spencer T. Predictors of persistence and remission of ADHD into adolescence: results from a four-year prospective follow-up study. *J Am Acad Child Adolesc Psychiatry*. 1996;35(3):343-351.
 14. Biederman J, Faraone SV, Mick E, Spencer T, Wilens T, Kiely K, Guite J, Ablon JS, Reed E, Warburton R. High risk for attention deficit hyperactivity disorder among children of parents with childhood onset of the disorder: a pilot study. *Am J Psychiatry*. 1995;152(3):431-435.
 15. Faraone SV, Biederman J, Monuteaux MC. Toward guidelines for pedigree selection in genetic studies of attention deficit hyperactivity disorder. *Genet Epidemiol*. 2000;18(1):1-16.
 16. Faraone SV. Genetics of adult attention-deficit/hyperactivity disorder. *Psychiatr Clin North Am*. 2004;27(2):303-321.
 17. Kuntsi J, Rijdsdijk F, Ronald A, Asherson P, Plomin R. Genetic influences on the stability of attention-deficit/hyperactivity disorder symptoms from early to middle childhood. *Biol Psychiatry*. 2005;57(6):647-654.
 18. Larsson H, Lichtenstein P, Larsson JO. Genetic contributions to the development of ADHD subtypes from childhood to adolescence. *J Am Acad Child Adolesc Psychiatry*. 2006;45(8):973-981.
 19. Price TS, Simonoff E, Asherson P, Curran S, Kuntsi J, Waldman I, Plomin R. Continuity and change in preschool ADHD symptoms: longitudinal genetic analysis with contrast effects. *Behav Genet*. 2005;35(2):121-132.
 20. Rietveld MJ, Hudziak JJ, Bartels M, van Beijsterveldt CE, Boomsma DI. Heritability of attention problems in children: longitudinal results from a study of twins, age 3 to 12. *J Child Psychol Psychiatry*. 2004;45(3):577-588.
 21. Derks EM, Hudziak JJ, Dolan CV, van Beijsterveldt TC, Verhulst FC, Boomsma DI. Genetic and environmental influences on the relation between attention problems and attention deficit hyperactivity disorder. *Behav Genet*. 2008;38(1):11-23.
 22. Hudziak JJ, Copeland W, Stanger C, Wadsworth M. Screening for *DSM-IV* externalizing disorders with the Child Behavior Checklist: a receiver-operating characteristic analysis. *J Child Psychol Psychiatry*. 2004;45(7):1299-1307.
 23. Biederman J, Wozniak J, Kiely K, Ablon S, Faraone S, Mick E, Mundy E, Kraus I. CBCL clinical scales discriminate prepubertal children with structured interview-derived diagnosis of mania from those with ADHD. *J Am Acad Child Adolesc Psychiatry*. 1995;34(4):464-471.
 24. Achenbach TM. *Manual for the Child Behavior Checklist/4-18 and 1991 Profile*. Burlington: University of Vermont, Department of Psychiatry; 1991.
 25. Achenbach TM. *Manual for the Youth Self-Report and 1991 Profile*. Burlington: University of Vermont, Department of Psychiatry; 1991.
 26. Achenbach TM, Rescorla LA. *Manual for the ASEBA Adult Forms and Profiles*. Burlington: University of Vermont, Research Center for Children, Youth and Families; 2003.
 27. Lichtenstein P, Tuvblad C, Larsson H, Carlström E. The Swedish Twin study of CHild and Adolescent Development: the TCHAD-study. *Twin Res Hum Genet*. 2007;10(1):67-73.
 28. Tuvblad C, Narusyte J, Grann M, Sarnecki J, Lichtenstein P. The genetic and environmental etiology of antisocial behavior from childhood to emerging adulthood. *Behav Genet*. 2011;41(5):629-640.
 29. Biederman J, Faraone SV, Doyle A, Lehman BK, Kraus I, Perrin J, Tsuang MT. Convergence of the Child Behavior Checklist with structured interview-based psychiatric diagnoses of ADHD children with and without comorbidity. *J Child Psychol Psychiatry*. 1993;34(7):1241-1251.
 30. Kendler KS, Gardner CO, Lichtenstein P. A developmental twin study of symptoms of anxiety and depression: evidence for genetic innovation and attenuation. *Psychol Med*. 2008;38(11):1567-1575.
 31. Muthén LK, Muthén BO. *Mplus User's Guide*. 4th ed. Los Angeles, CA: Muthén & Muthén; 1998-2006.
 32. Kendler KS, Gardner CO, Annas P, Neale MC, Eaves LJ, Lichtenstein P. A longitudinal twin study of fears from middle childhood to early adulthood: evidence for a developmentally dynamic genome. *Arch Gen Psychiatry*. 2008;65(4):421-429.
 33. Neale MC, Boker SM, Xie G, Maes HH. *Mx: Statistical Modeling*. 6th ed. Richmond: Department of Psychiatry, Virginia Institute for Psychiatric and Behavioral Genetics, Virginia Commonwealth University; 2003.
 34. Markon KE, Krueger RF. An empirical comparison of information-theoretic selection criteria for multivariate behavior genetic models. *Behav Genet*. 2004;34(6):593-610.
 35. Baker LA, Jacobson KC, Raine A, Lozano DI, Bezdjian S. Genetic and environmental bases of childhood antisocial behavior: a multi-informant twin study. *J Abnorm Psychol*. 2007;116(2):219-235.
 36. Burt SA, Krueger RF, McGue M, Iacono W. Parent-child conflict and the comorbidity among childhood externalizing disorders. *Arch Gen Psychiatry*. 2003;60(5):505-513.
 37. Achenbach TM, McConaughy SH, Howell CT. Child/adolescent behavioral and emotional problems: implications of cross-informant correlations for situational specificity. *Psychol Bull*. 1987;101(2):213-232.
 38. Ehringer MA, Rhee SH, Young S, Corley R, Hewitt JK. Genetic and environmental contributions to common psychopathologies of childhood and adolescence: a study of twins and their siblings. *J Abnorm Child Psychol*. 2006;34(1):1-17.
 39. Martin N, Scourfield J, McGuffin P. Observer effects and heritability of childhood attention-deficit hyperactivity disorder symptoms. *Br J Psychiatry*. 2002;180:260-265.
 40. Alberts-Corush J, Firestone P, Goodman JT. Attention and impulsivity characteristics of the biological and adoptive parents of hyperactive and normal children. *Am J Orthopsychiatry*. 1986;56(3):413-423.
 41. Curko Kera EA, Marks DJ, Berwid OG, Santra A, Halperin JM. Self-report and objective measures of ADHD-related behaviors in parents of preschool children at risk for ADHD. *CNS Spectr*. 2004;9(9):639-647.
 42. Epstein JN, Conners CK, Erhardt D, Arnold LE, Hechtman L, Hinshaw SP, Hoza B, Newcorn JH, Swanson JM, Vitiello B. Familial aggregation of ADHD characteristics. *J Abnorm Child Psychol*. 2000;28(6):585-594.
 43. Johansson S, Halletland H, Halmøy A, Jacobsen KK, Landaas ET, Dramsdahl M, Fasmer OB, Bergsholm P, Lundervold AJ, Gillberg C, Ugedahl K, Knappskog PM, Haavik J. Genetic analyses of dopamine related genes in adult ADHD patients suggest an association with the DRD5-microsatellite repeat, but not with DRD4 or SLC6A3 VNTRs. *Am J Med Genet B Neuropsychiatr Genet*. 2008;147B(8):1470-1475.
 44. Ribasés M, Hervás A, Ramos-Quiroga JA, Bosch R, Bielsa A, Gastaminza X, Fernández-Anguiano M, Nogueira M, Gómez-Barros N, Valero S, Gratacòs M, Estivill X, Casas M, Cormand B, Bayés M. Association study of 10 genes encoding neurotrophic factors and their receptors in adult and child attention-deficit/hyperactivity disorder. *Biol Psychiatry*. 2008;63(10):935-945.
 45. Biederman J, Petty CR, Ten Haagen KS, Small J, Doyle AE, Spencer T, Mick E, Monuteaux MC, Smoller JW, Faraone SV. Effect of candidate gene polymorphisms on the course of attention deficit hyperactivity disorder. *Psychiatry Res*. 2009;170(2-3):199-203.
 46. Thapar A, Langley K, Asherson P, Gill M. Gene-environment interplay in attention-deficit hyperactivity disorder and the importance of a developmental perspective. *Br J Psychiatry*. 2007;190:1-3.
 47. Halperin JM, Schulz KP. Revisiting the role of the prefrontal cortex in the pathophysiology of attention-deficit/hyperactivity disorder. *Psychol Bull*. 2006;132(4):560-581.
 48. Halperin JM, Trampush JW, Miller CJ, Marks DJ, Newcorn JH. Neuropsychological outcome in adolescents/young adults with childhood ADHD: profiles of persisters, remitters and controls. *J Child Psychol Psychiatry*. 2008;49(9):958-966.
 49. Shaffer D. Attention deficit hyperactivity disorder in adults. *Am J Psychiatry*. 1994;151(5):633-638.
 50. Moffitt TE, Caspi A, Dickson N, Silva P, Stanton W. Childhood-onset versus adolescent-onset antisocial conduct problems in males: natural history from ages 3 to 18 years. *Dev Psychopathol*. 1996;8(2):399-424. doi:http://dx.doi.org/10.1017/S0954579400007161.
 51. Barkley RA, Fischer M, Smallish L, Fletcher K. The persistence of attention-deficit/hyperactivity disorder into young adulthood as a function of reporting source and definition of disorder. *J Abnorm Psychol*. 2002;111(2):279-289.
 52. Smith BH, Pelham WE Jr, Gnagy E, Molina B, Evans S. The reliability, validity, and unique contributions of self-report by adolescents receiving treatment for attention-deficit/hyperactivity disorder. *J Consult Clin Psychol*. 2000;68(3):489-499.
 53. Murphy P, Schachar R. Use of self-ratings in the assessment of symptoms of attention deficit hyperactivity disorder in adults. *Am J Psychiatry*. 2000;157(7):1156-1159.
 54. Achenbach TM, Bernstein A, Dumenci L. *DSM-oriented scales and statistically based syndromes for ages 18 to 59: linking taxonomic paradigms to facilitate multitaxonomic approaches*. *J Pers Assess*. 2005;84(1):49-63.
 55. Achenbach TM, Dumenci L, Rescorla LA. *DSM-oriented and empirically based approaches to constructing scales from the same item pools*. *J Clin Child Adolesc Psychol*. 2003;32(3):328-340.